

BACKFLOW PREVENTION AND CROSS-CONNECTION CONTROL

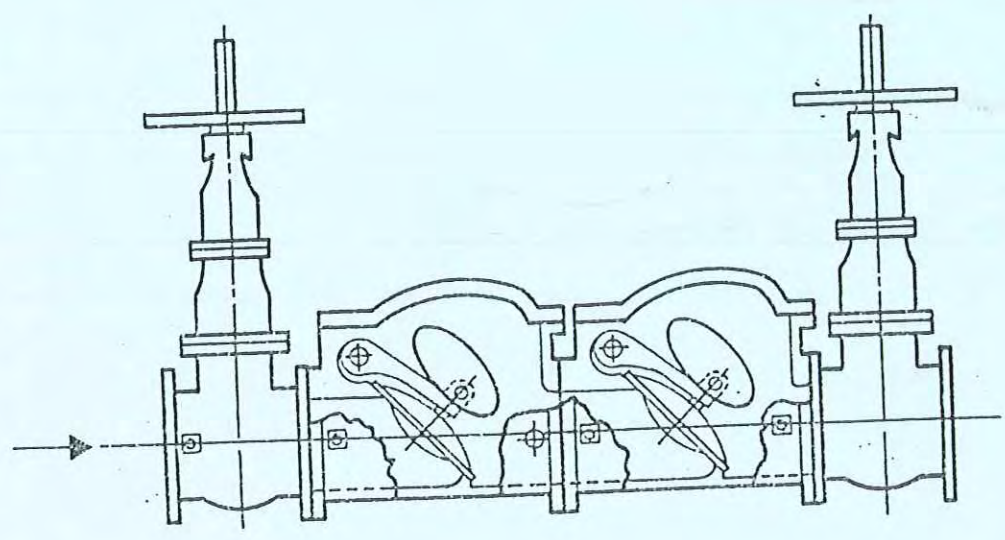
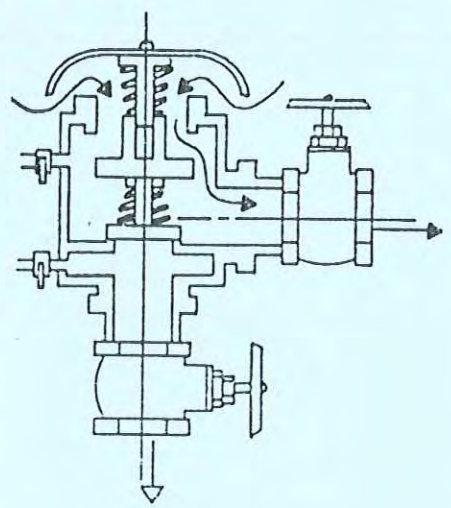
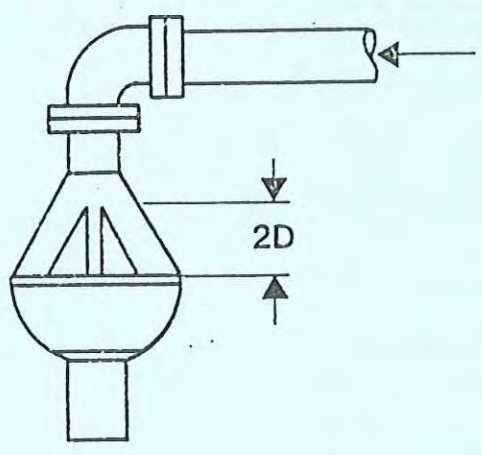

TABLE OF CONTENTS

Resolution	1
General Regulations:	
Policy	4
Definitions	5
Water System	10
Surveys and Investigations	14
Protection Required	15
Devices	23
Installation	31
Inspection & Maintenance	34
Booster Pumps	41
Violations	45
Approved List of Devices	46
Cross-Connection Control & Containment Device Program	55
Customer Questionnaire	62

RESOLUTION NO. 95-13

In the matter of providing an effective means for protecting the public water system from contamination due to backflow of contaminants through the water service connection into the public water system.

} Wood County Regional
} Water and Sewer District
} February 14, 1995
}

Trustee Greene moved the adoption of the following Resolution:

WHEREAS, Section 6109.13 of the Ohio Revised Code requires protection of the public water system from contamination through any connection whereby water from a private, auxiliary or emergency water system may enter the public water system; and

WHEREAS, Section 3745-95 of the Ohio Administrative Code requires protection of the public water system from contamination due to backflow of contaminants through the water service connection; and

WHEREAS, The Ohio Environmental Protection Agency requires the maintenance of a continuing program of cross-connection control which will systematically and effectively prevent the contamination of all potable water systems; and

WHEREAS, in order to accomplish these goals it is necessary to introduce restrictions that go beyond usual plumbing code requirements; therefore be it

RESOLVED, By the Board of Trustees of the Wood County Regional Water and Sewer District:

Section 1. That if, in the judgement of the Executive Director and Superintendent, an approved backflow prevention device is necessary for the safety of the public water system, the Executive Director or Superintendent will give notice to the water consumer to install such an approved device immediately. The water consumer shall, at his own expense, install such an approved device at a location and in a manner approved by the District and shall have inspections and tests made of such approved devices as required by the District.

Section 2. That no person, firm or corporation shall establish or permit to be established or maintain or permit to be maintained any connection whereby a private, auxiliary or emergency water supply other than the regular public water supply of the Wood County Regional Water and Sewer District may enter the supply or distributing system of said municipality, unless such private, auxiliary or emergence water supply and the method of connection and use of such supply shall have been approved by the Executive Director of the District and by the Ohio Environmental Protection Agency.

Section 3. That it shall be the duty of the District to cause surveys and investigations to be made of industrial and other properties served by the public water supply where actual or potential hazards to the public water supply may exist. Such surveys and investigations shall be made a matter of public record and shall be repeated as often as the Executive Director shall deem necessary.

Section 4. That the Executive Director of the Wood County Regional Water and Sewer District, or his or its duly authorized representative shall have the right to enter at any reasonable time any property served by a connection to the public water supply or distribution system of the District for the purpose of inspecting the piping system or systems thereof. On demand the owner, lessees or occupants of any property so served shall furnish to the Executive Director any information which he may request regarding the piping system or systems or water use on such property. The refusal of such information, when demanded, shall, within the discretion of the Executive Director, be deemed evidence of the presence of improper connections as provided in this resolution.

Section 5. That the Executive Director of the District is hereby authorized and directed to discontinue, after reasonable notice to the occupant thereof, the water service to any property wherein any connection in violation of the provisions of this ordinance is known to exist, and to take such other precautionary measures as he may deem necessary to eliminate any danger of contamination of the public water supply distribution mains. Water service to such property shall not be restored until such conditions shall have been eliminated or corrected in compliance with the provisions of this resolution.

and be it further

RESOLVED, That the Board of Trustees of the Wood County Regional Water and Sewer District hereby finds and determines that all formal actions relative to the passage of this resolution were taken in open meetings of this Board, and that all deliberations of the Board and of its committees, if any, which resulted in formal action, were taken in meetings open to the public, in full compliance with applicable legal requirements, including Section 121.22, Ohio Revised Code.

Trustee Aust seconded the resolution and the roll being called on its

adoption, the vote resulted as follows:

YES 7

NO 0

 Henry F. Meyer
President

 Justin Bowen
Secretary

Attest: Debra M. Laurel
Clerk of the Board

BACKFLOW PREVENTION

=====

SECTION 1.

BACKFLOW PREVENTION - GENERAL POLICY

A. Purpose

The purpose of these Rules and Regulations is:

1. To protect the public potable water supply from contamination or pollution by isolating within the consumer's water system contaminants or pollutants which could backflow through the service connection into the public potable water system.
2. To promote the elimination or control of existing cross-connections, actual or potential, between the public or consumer's potable water system and nonpotable water systems, plumbing fixtures and sources or systems containing process fluids.
3. To provide for the maintenance of a continuing program of cross-connection control which will systematically and effectively prevent the contamination or pollution of the public and consumer's potable water system.

B. Application

These Rules and Regulations shall apply to all premises served by the public potable water system of the Wood County Regional Water & Sewer District.

C. Policy

The Superintendent of Water shall be responsible for the protection of the public potable water system from contamination due to backflow of contaminants through the water service connection. If, in the judgement of the Superintendent of Water, an approved backflow prevention device is necessary at the water service connection to any consumer's premises for the safety of the water system, the Superintendent of Water or his authorized representative shall give notice to the consumer to install such approved backflow prevention device at each service connection to his premises. The consumer shall immediately install such approved device or devices at this own expense, and failure, refusal or inability on the part of the consumer to install such device or devices immediately shall constitute grounds for discontinuing water service to the premises until such device or devices have been installed.

BACKFLOW PREVENTION

=====

SECTION 2.

DEFINITIONS

A. The following definitions shall apply in the interpretation and enforcement of these rules and regulations:

1. Air Gap Separation

means the unobstructed vertical distance through the free atmosphere between the lowest opening from any pipe or faucet supplying water to a tank, plumbing fixture, or other device and the flood level rim of the receptacle.

2. Approved

means that a backflow prevention device or method has been accepted by the supplier of water and the director as suitable for the proposed use.

3. Auxiliary Water Supply

means any water system on or available to the premises other than the public water system and includes the water supplied by the system. These auxiliary waters may include water from another source such as wells, lakes, or streams; or process fluids; or used water. They may be polluted or contaminated or objectionable or constitute a water source of system over which the supplier of water does not have control.

4. Backflow

means the flow of water or other liquids, mixtures, or substances into the distributing pipes of a potable water supply from any source other than the intended source of the potable water supply.

5. Backflow Prevention Device

means any device, method, or type of construction intended to prevent backflow into a potable water system.

BACKFLOW PREVENTION

=====

SECTION 2. Cont.

6. Consumer

means the owner or person in control of any premises supplied by or in any manner connected to a public water system.

7. Consumer's Water System

means any water system, located on the consumer's premises, supplied by or in any manner connected to a public water system. A household plumbing system is considered to be a consumer's water system.

8. Contamination

means an impairment of the quality of the water by sewage or process fluid or waste to a degree which could create an actual hazard to the public health through poisoning or through spread of disease by exposure.

9. Cross-connection

means any arrangement whereby backflow can occur.

10. Degree of Hazard

means the potential risk to health and the adverse effect upon the potable water system derived from an evaluation of that potential.

11. Director

means the director of environmental protection or his duly authorized representative.

12. Double Check Valve Assembly

means as assembly composed of two single, independently acting, check valves including tightly closing shutoff valves located at each end of the assembly and suitable connections for testing the water-tightness of each check valve.

BACKFLOW PREVENTION

=====

SECTION 2. Cont.

13. Health Hazard

means any condition, device, or practice in a water system or its operation that creates, or may create, a danger to the health and well-being of users. The word "severe" as used to qualify "health hazard" means a hazard to the health of the user that could reasonably be expected to result in significant morbidity or death.

14. Interchangeable Connection

means an arrangement or device that will allow alternate but not simultaneous use of two sources of water.

15. Non-potable Water

means water not safe for drinking, personal, or culinary use.

16. Person

means the state, any political subdivision, public or private corporation, individual, partnership, or other legal entity.

17. Pollution

means the presence in water of any foreign substance that tends to degrade its quality so as to constitute a hazard or impair the usefulness or quality of the water to a degree which does not create an actual hazard to the public health but which does adversely and unreasonable affect such waters for domestic use.

18. Potable Water

means water which is satisfactory for drinking, culinary, and domestic purposes and meets the requirements of the environmental protection agency.

19. Process Fluids

means any fluid or solution which may be chemically, biologically, or otherwise contaminated or polluted in a form or concentration such as would constitute a health, pollution, or system hazard if introduced into the public or a potable consumer's water system. This includes, but is not limited to:

BACKFLOW PREVENTION

=====

SECTION 2. Cont.

- a. Polluted or contaminated waters;
- b. Process waters;
- c. Used waters originating from the public water system which may have deteriorated in sanitary quality;
- d. Cooling waters;
- e. Contaminated natural waters taken from wells, lakes, streams, or irrigation systems;
- f. Chemicals in solution or suspension;
- g. Oils, gases, acids, alkalis, and other liquid and gaseous fluids used in industrial or other processes, or for fire fighting purposes.

20. Public Water System

means that which is ascribed to such term in rule 3745-81-01 of the Administrative Code.

21. Reduced Pressure Principle Backflow Prevention Device

means a device containing a minimum of two independently acting check valves together with an automatically operated pressure differential relief valve located between two check valves. During normal flow and at the cessation of normal flow, the pressure between these two checks shall be less than the supply pressure. In case of leakage of either check valve, the differential relief valve, by discharging to the atmosphere, shall operate to maintain the pressure between the check valves at less than the supply pressure. The unit must include tightly closing shutoff valves located at each end of the device, and each device shall be fitted with properly located test cocks.

22. Service Connection

means the terminal end of a service line from the public water system. If a meter is installed at the end of the service, then the service connection means the downstream end of the meter.

23. Supplier of Water

means the owner or operator of a public water system.

24. System Hazard

means a condition posing an actual or potential threat of damage to the physical properties of the public water system or a potable consumer's water system.

BACKFLOW PREVENTION

=====

SECTION 2. Cont.

25. Pollutional Hazard

means a condition through which an aesthetically objectionable or degrading material not dangerous to health may enter the public water system or a potable consumer's water system.

26. Used Water

means any water supplied by a supplier of water from a public water system to a consumer's water system after it has passed through the service connection and is no longer under the control of the supplier.

BACKFLOW PREVENTION

=====

SECTION 3.

WATER SYSTEM

- A. The water system shall be considered as made up of two parts: the public potable water system and the consumer's water system.
- B. The public potable water system shall consist of the source facilities and the distribution system, and shall include all those facilities of the potable water system under the control of the Superintendent of Water up to the point where the consumer's water system begins.
- C. The source shall include all components of the facilities utilized in the production treatment, storage and delivery of water to the public distribution system.
- D. The public distribution system shall include the network of conduits used for delivery of water from the source to the consumer's water system.
- E. The consumer's water system shall include those parts of the facilities beyond the service connection which are utilized in conveying water from the public distribution system to points of use.

DETERMINING POINT OF REGULATORY RESPONSIBILITY AND AUTHORITY

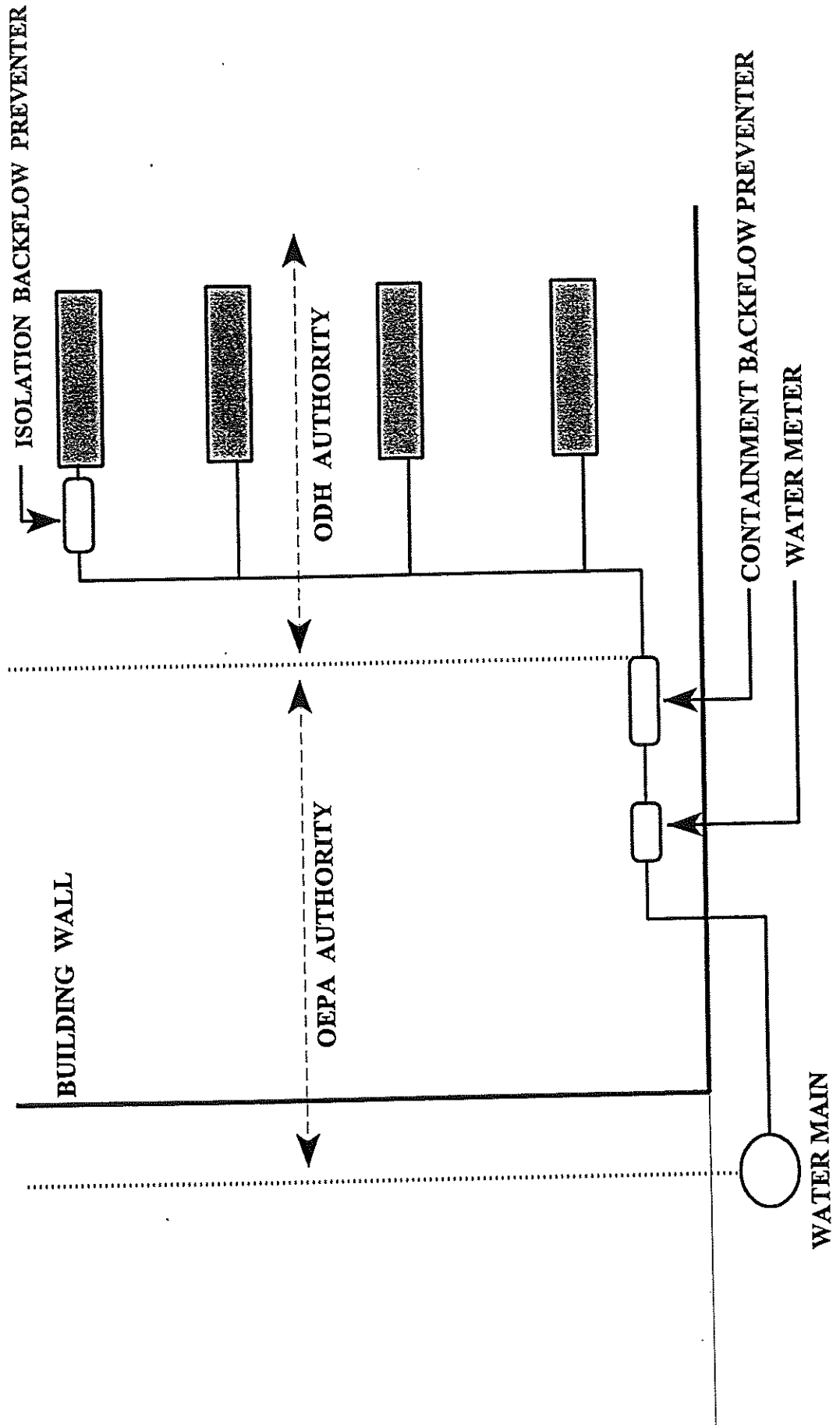

BACKFLOW PREVENTION

=====

SECTION 4.

CROSS-CONNECTIONS PROHIBITED

- A. No water service connection shall be installed or maintained to any premises where actual or potential cross-connections to the public potable or consumer's water system may exist unless such actual or potential cross-connections are abated or controlled to the satisfaction of the Superintendent of Water.

- B. No connection shall be installed or maintained whereby water from an auxiliary water system may enter a public potable or consumer's water system unless such auxiliary water system and the method of connection and use of such system shall have been approved by the Superintendent of Water and by the Director of the Ohio Environmental Protection Agency as required by Section 6109.13 of the Ohio Revised Code.

BACKFLOW PREVENTION VS CROSS-CONNECTION CONTROL

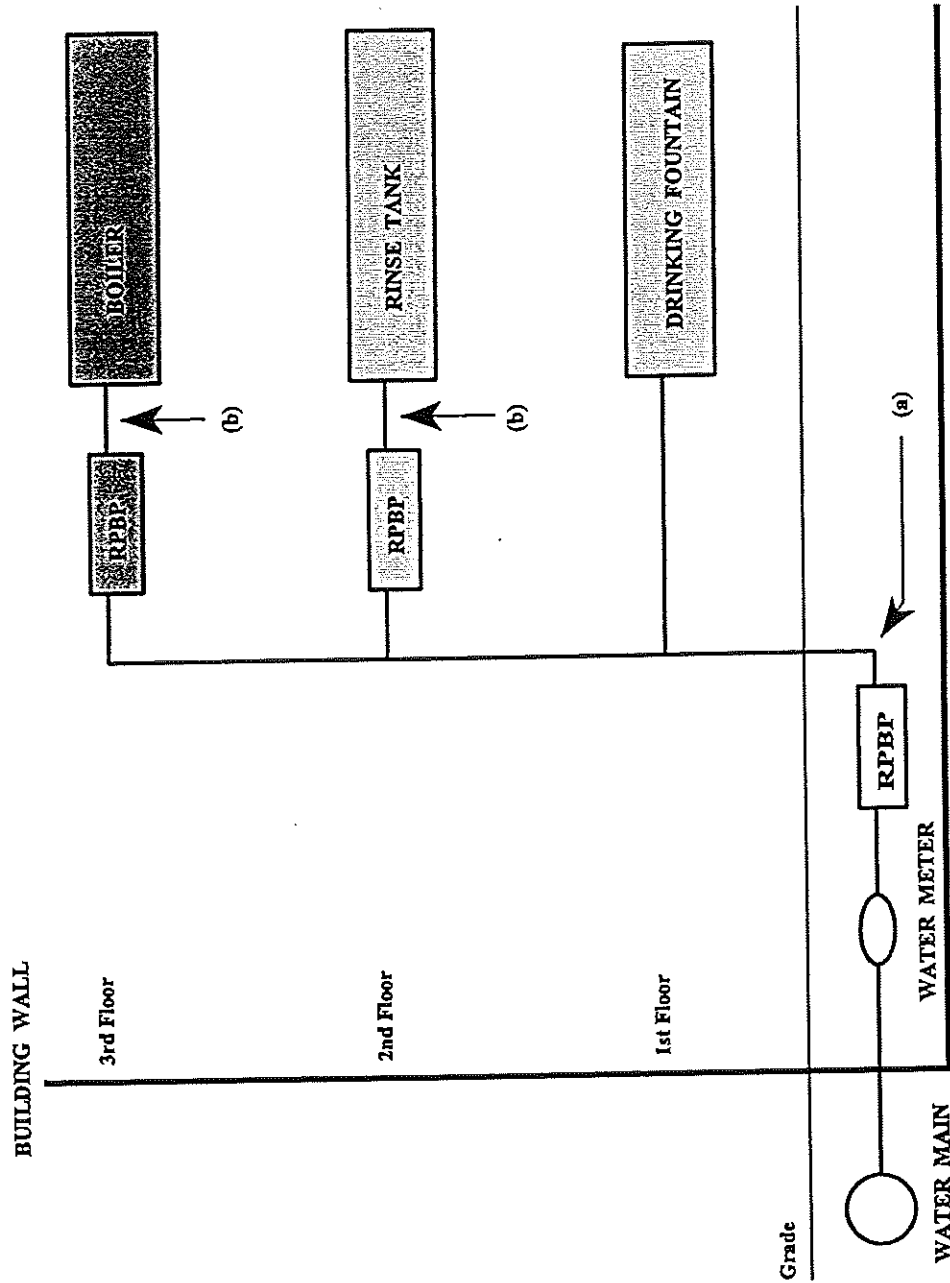

(a) Point of Backflow: Backflow means the flow of water or other liquids, mixtures, or substances into the distribution pipes of a potable water supply from any source other than the intended source of the potable water supply.

(b) Point of Cross-Connection: Cross-connection means any arrangement whereby backflow can occur.

BACKFLOW PREVENTION

=====

SECTION 5.

SURVEY AND INVESTIGATIONS

- A. The consumer's premises shall be open at all reasonable times to the Superintendent of Water, or his authorized representative, for the conduction of surveys and investigations of water use practices within the consumer's premises to determine whether there are actual or potential cross-connections to the consumer's water system through which contaminants or pollutants could backflow into the public potable water system.

- B. On request by the Superintendent of Water, or his authorized representative, the consumer shall furnish information on water use practices within his premises.

- C. It shall be the responsibility of the water consumer to conduct periodic surveys of water use practices on his premises to determine whether there are actual or potential cross-connections in his water system through which contaminants or pollutants could backflow into his or the public potable water system.

BACKFLOW PREVENTION

=====

SECTION 6.

WHERE PROTECTION IS REQUIRED

- A. An approved backflow prevention device shall be installed on each service line to a consumer's water system serving premises, where in the judgement of the Superintendent of Water of the District, actual or potential hazards to the public potable water system exist.

- B. An approved backflow prevention device shall be installed on each service line to a consumer's water system serving premises where the following conditions exist:
 - 1. Premises having an auxiliary water system, unless such auxiliary system is accepted as an additional source by the Superintendent of Water and the source is approved by the Director of the Ohio Environmental Protection Agency;
 - 2. Premises on which any substance is handled in such a fashion as to create an actual or potential hazard to the public potable water system. This shall include premises having sources or systems containing process fluids or waters originating from the public potable water system which are no longer under the sanitary control of the Superintendent of Water;
 - 3. Premises having internal cross-connections that, in the judgement of the Superintendent of Water, are not correctable, or intricate plumbing arrangements which make it impractical to determine whether or not cross-connections exist;
 - 4. Premises where, because of security requirements or other prohibitions or restrictions, it is impossible or impractical to make a complete cross-connection survey;
 - 5. Premises having a repeated history of cross-connections being established or re-established;
 - 6. Others specified by the Superintendent of Water or the Director.

- C. An approved backflow prevention device shall be installed on each service line to a consumer's water system serving, but not necessarily limited to, the following types of facilities unless the Superintendent of Water or the District determines that no actual or potential hazard to the public potable water system exists:

BACKFLOW PREVENTION

=====

SECTION 6. Cont.

1. Hospitals, mortuaries, clinics, nursing homes;
 2. Laboratories
 3. Piers, docks, waterfront facilities;
 4. Sewage treatment plants, sewage pumping stations or storm water pumping stations;
 5. Food or beverage processing plants;
 6. Chemical plants;
 7. Metal plating industries;
 8. Petroleum processing or storage plants;
 9. Radioactive material processing plants or nuclear reactors;
 10. Car washes;
 11. Others specified by the Superintendent of Water or the Director
- D. An approved backflow prevention device shall be installed at any point of connection between the public potable or consumer's water system and an auxiliary water system, unless such auxiliary system is accepted as an additional source by the Superintendent of Water and the source is approved by the Director of the Ohio Environmental Protection Agency.

BACKFLOW PREVENTION DEVICES PROTECTION AGAINST HAZARDS

TYPE OF FACILITY	MINIMUM TYPE OF PROTECTION
Agricultural	Air Gap Separation
Bottling Plants	Reduced Pressure Assembly
Breweries	Reduced Pressure Assembly
Canneries	Reduced Pressure Assembly
Car Wash (with recycling system or soap/wax eductors)	Reduced Pressure Assembly
Chemical Plants	Reduced Pressure Assembly OR Air Gap Separation
Chemically Treated Boilers or Cooling Systems	Reduced Pressure Assembly OR Air Gap Separation
Covered Gravity or Pressure Storage Tanks (filled with water from the public system and for domestic use only)	Double Check Assembly
Dairies	Reduced Pressure Assembly
Dentist Office	Reduced Pressure Assembly
Domestic Pumps	Low Pressure Cut-off Controller
Dry Cleaning Plants	Reduced Pressure Assembly
Dye Plants	Air Gap Separation
Fertilizer Plant	Reduced Pressure Assembly
Film Laboratory	Reduced Pressure Assembly
Hospitals or Medical Buildings	Reduced Pressure Assembly OR Air Gap Separation
Irrigation Systems	Reduced Pressure Assembly
Laundries (Commercial)	Reduced Pressure Assembly
Machine Tool Plants	Reduced Pressure Assembly
Marine Facilities	Reduced Pressure Assembly
Meat Packing Houses	Reduced Pressure Assembly

Metal Processing Plants	Reduced Pressure Assembly
Metal Plating Plants	Reduced Pressure Assembly
Morgues	Air Gap Separation
Mortuaries	Air Gap Separation
Multistoried Buildings	Double Check Assembly
Nursing Homes	Reduced Pressure Assembly
Oil and Gas Facilities	Reduced Pressure Assembly
Paper Products Plant	Reduced Pressure Assembly
Pharmaceutical Plant	Reduced Pressure Assembly
Piers, Docks, or Waterfront Facilities	Reduced Pressure Assembly
Power Generating Facilities	Reduced Pressure Assembly
Radioactive Material Facilities	Air Gap Separation
Restaurants (with soap eductors or commercial disposal)	Reduced Pressure Assembly
Restricted Access Facilities	Reduced Pressure Assembly
Sand/Gravel Plants	Double Check Assembly
Schools	Reduced Pressure Assembly
Self-draining Hydrants	Double Check Assembly OR Reduced Pressure Assembly
Sewage Treatment Plants	Reduced Pressure Assembly
Sewage Treatment Plant Sewage Pumps	Air Gap Separation
Solar Systems	Double Check Assembly OR Reduced Pressure Assembly
Swimming Pools	Air Gap Separation
Uncovered Tanks or Reservoirs	Air Gap Separation
Veterinary Establishments	Reduced Pressure Assembly
Water Haulers	Air Gap Separation

BACKFLOW PREVENTION DEVICES PROTECTION AGAINST HAZARDS

The following guide is a general recommendation for internal isolation protection.

NOTE:

- AG....Air Gap
- AVB...Atmospheric Vacuum Breaker
- DCA...Double Check Assembly
- PVB...Pressure Vacuum Breaker
- RPA...Reduced Pressure Assembly

*..... AVBs and PVBs may be used to isolate health hazards under certain conditions; that is, backsiphonage situations.

**..... Where a greater hazard exists (because of toxicity or other potential health impact), additional area protection with RPAs is required.

DESCRIPTION OF CROSS- CONNECTION	HAZARD	ASSEMBLY
Aspirator	Health	AVB or PVB
Bedpan Washers	Health	AVB or PVB
Autoclaves	Health	RPA
Specimen Tanks	Health	AVB or PVB
Sterilizers	Health	RPA
Cuspidors	Health	AVB or PVB
Lab Bench Equipment	Health	AVB or PVB
Sewage Pump	Health	AG
Connection to Plating Tanks	Health	AG
Connection to Salt Water Cooling System	Health	RPA
Tank Vats or Other Vessels Containing Toxic Substances	Health	RPA, AG
Dye Vats or Machines	Health	AG
Cooling Towers with Chemical Additives	Health	AG

DESCRIPTION OF CROSS-CONNECTION	HAZARD	ASSEMBLY
Trap Primer	Health	AG
Steam Generators	Nonhealth**	RPA
Heating Equipment		
Commercial	Nonhealth**	RPA
Domestic	Nonhealth**	DCA
Irrigations Systems	Nonhealth**	RPA, AVB, PVB
Swimming Pools		
Public	Nonhealth**	AG
Private	Nonhealth**	AG
Vending Machines	Nonhealth**	RPA, PVB
Ornamental Fountains	Nonhealth**	DCA, AVB, PVB
Degreasing Equipment	Nonhealth**	DCA
Lab Bench Equipment	Nonhealth**	AVB, PVB
Hose Bibbs	Nonhealth**	AVB
Trap Primers	Nonhealth**	AG
Flexible Shower Heads	Nonhealth**	AVB, PVB
Steam Tables	Nonhealth**	AVB
Washing Equipment	Nonhealth**	AVB
Shampoo Basins	Nonhealth**	AVB
Kitchen Equipment	Nonhealth**	AVB
Aspirators	Nonhealth**	AVB

BACKFLOW PREVENTION

=====

SECTION 7.

TYPE OF PROTECTION REQUIRED

A. The type of protection required under Sections 6.A, 6.B, and 6.C of these regulations shall depend on the **DEGREE OF HAZARD** which exists as follows:

1. An approved air gap separation shall be installed where the public potable water system may be contaminated with substances that could cause a **SEVERE HEALTH HAZARD**;
2. An approved air gap separation or an approved reduced pressure principle backflow prevention device shall be installed where the public potable water system may be contaminated with any substance that could cause a **SYSTEM OR HEALTH HAZARD**;
3. An approved air gap separation or an approved reduced pressure principle backflow prevention device or an approved double check valve assembly shall be installed where the public potable water system may be polluted with substances that could cause a **POLLUTIONAL HAZARD** not dangerous to health.

B. The type of protection required under Section 6.D of these regulations shall be an approved air gap separation or an approved interchangeable connection.

C. Where an auxiliary water system is used as a secondary source or water for a fire protection system, the provisions of Section 7.B for an approved air gap separation or an approved interchangeable connection may not be required, provided:

1. At premises where the auxiliary water system may be contaminated by substances that could cause a system or health hazard, the public or consumer's potable water system shall be protected against backflow by installation of an approved reduced pressure principle backflow prevention device;
2. At all other premises, the public or consumer's potable water system shall be protected against backflow by installation of either an approved reduced pressure principle backflow prevention device or an approved double check valve assembly;
3. The public or consumer's potable water system shall be the primary source of water for the fire protection system;

4. The fire protection system shall be normally filled with water from the public or consumer's potable water system;
5. The water in the fire protection system shall be used for fire protection only, with no regular use of water from the fire protection system downstream from the approved backflow prevention device;
6. The water in the fire protection system shall contain no additives.

BACKFLOW PREVENTION

=====

SECTION 8.

TYPE OF PROTECTION REQUIRED

A. Any backflow prevention device required by these rules and regulations shall be of a model or construction approved by the Superintendent of Water or the Director and shall comply with the following:

1. An air gap separation, to be approved, shall be at least twice the diameter of the supply pipe, measured vertically above the top rim of the vessel, but in no case less than one inch.
2. A double check valve assembly or a reduced pressure principle backflow prevention device shall be approved by the Superintendent of Water, and shall appear on the current list of approved backflow prevention devices of the Ohio Environmental Protection Agency.
3. An interchangeable connection, to be approved, shall be either a swing type connector or a four-way valve of the lubricated plug type that operates through a mechanism which unseats the plug, turns it ninety degrees and reseats the plug. Four-way valves shall not be used as stop valves but must have separate stop valves on each pipe connected to the valve. The telltale port on the four-way valve shall have no piping connected and the threads or flange on this port shall be destroyed so that a connection cannot be made.

B. Existing backflow prevention devices approved by the Superintendent of Water or the Director of the Ohio Environmental Protection Agency at the time of installation and properly maintained shall, except for inspection, testing and maintenance requirements, be excluded from the requirement of Section 8.A of this regulation providing the Superintendent of Water is assured that they will satisfactorily protect the public potable water system. Whenever the existing device is moved from the present location or requires more than minimum maintenance or when the Superintendent of Water finds that the maintenance of the device constitutes a hazard to health, the device shall be replaced by a backflow prevention device meeting the requirements of these regulations.

INSTALLING AN APPROVED AIR GAP SEPARATION

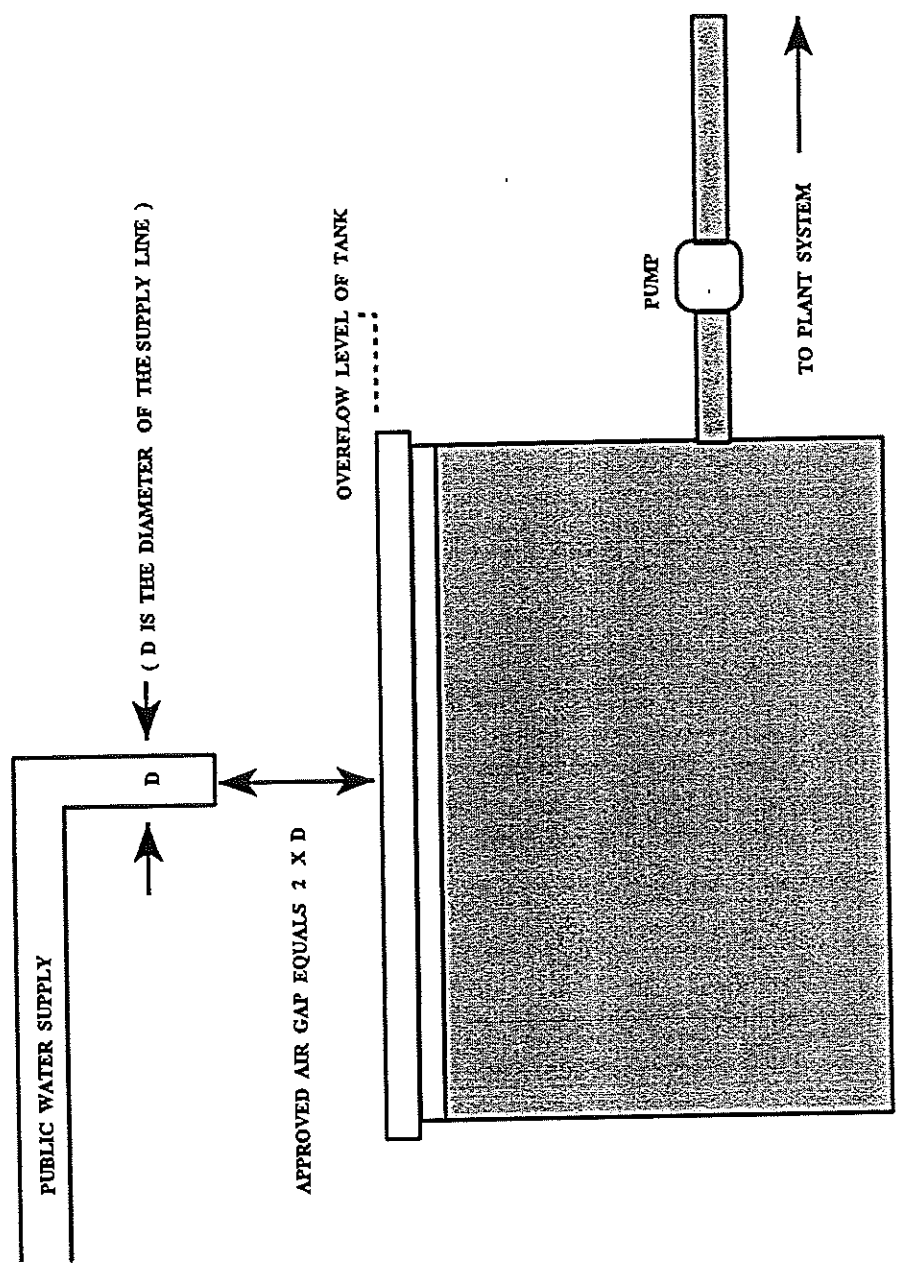

1. A properly designed and installed air gap separation provides the maximum protection against backflow.
2. The minimum approved air gap separation is one inch.

INTERCONNECTION OF AUXILIARY AND PUBLIC WATER SUPPLY

--- SWING CONNECTOR INSTALLATION ---

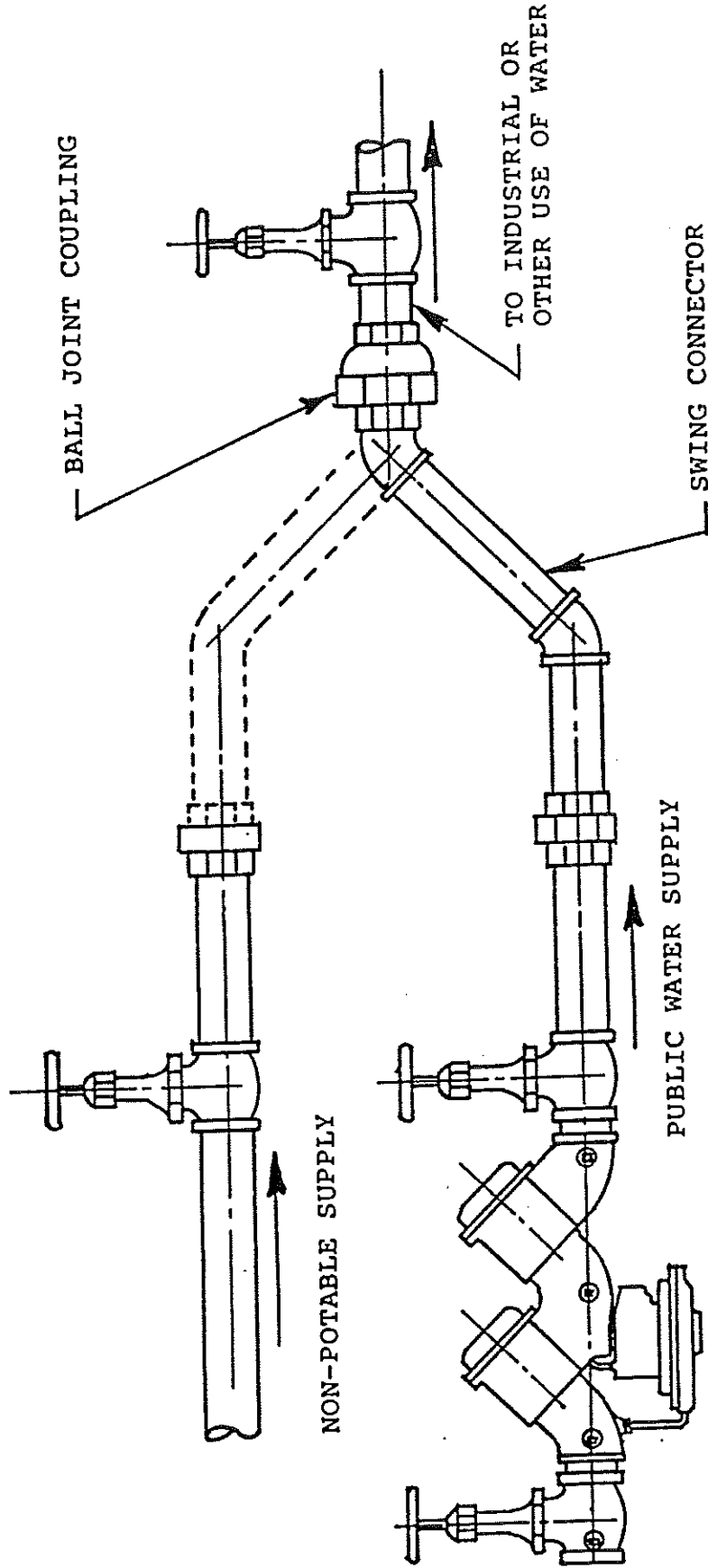

1. A reduced pressure principle backflow preventer must be installed on the public water supply line, at the point of interconnection with the auxiliary water source and at the point the public water supply enters the building (containment principle).
2. A separate shut-off control valve must be installed on each piping leg of the swing connection.

INTERCONNECTION OF AUXILIARY AND PUBLIC WATER SUPPLY

--- FOUR-WAY VALVE INSTALLATION ---

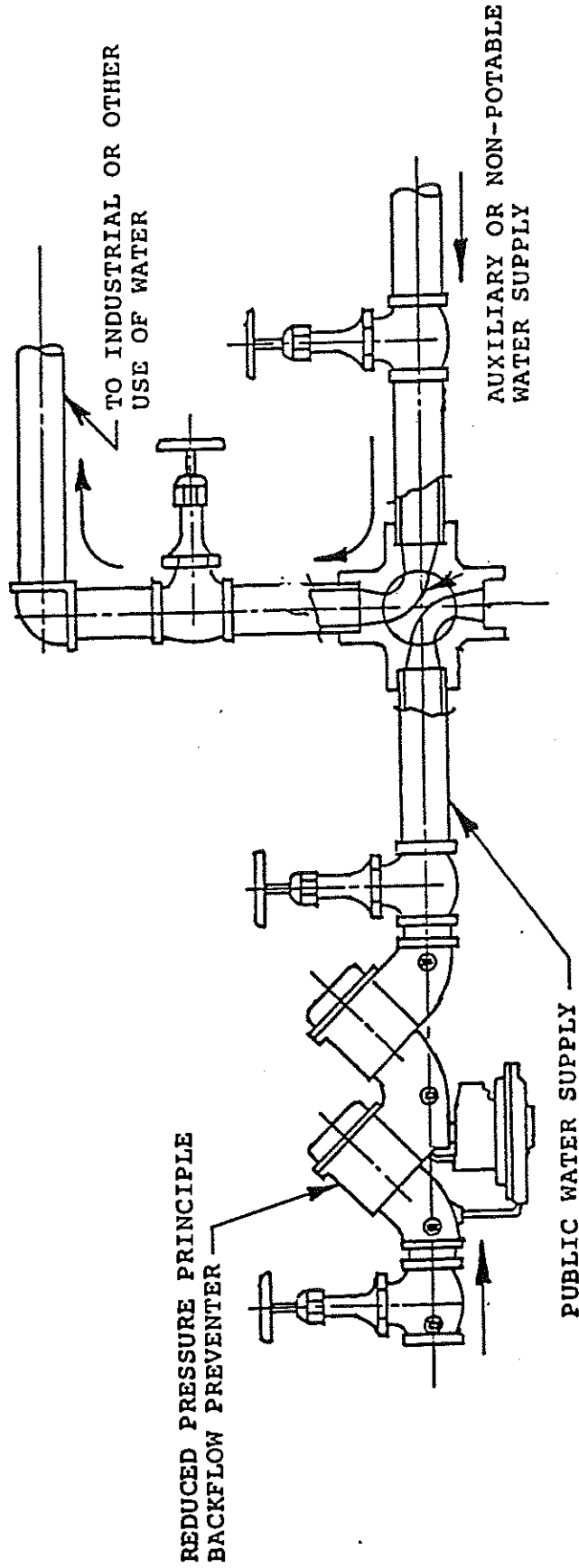

1. The four-way valve must be a lubricated plug, 4 way, 4 port, 90 degree turn, 2 position type valve.
2. A reduced pressure principle backflow preventer must be installed on the public water supply line, at the point of interconnection with the auxiliary water source and at the point the public water supply enters the building (containment principle).
3. A separate shut-off control valve must be installed on each piping leg of the four-way valve connection.
4. The four-way valve discharge port must be in a horizontal or vertically downward discharging position.
5. There may be no piping or valve connections to the discharge port.

TEST CONNECTIONS FOR DOUBLE CHECK BACKFLOW PREVENTER

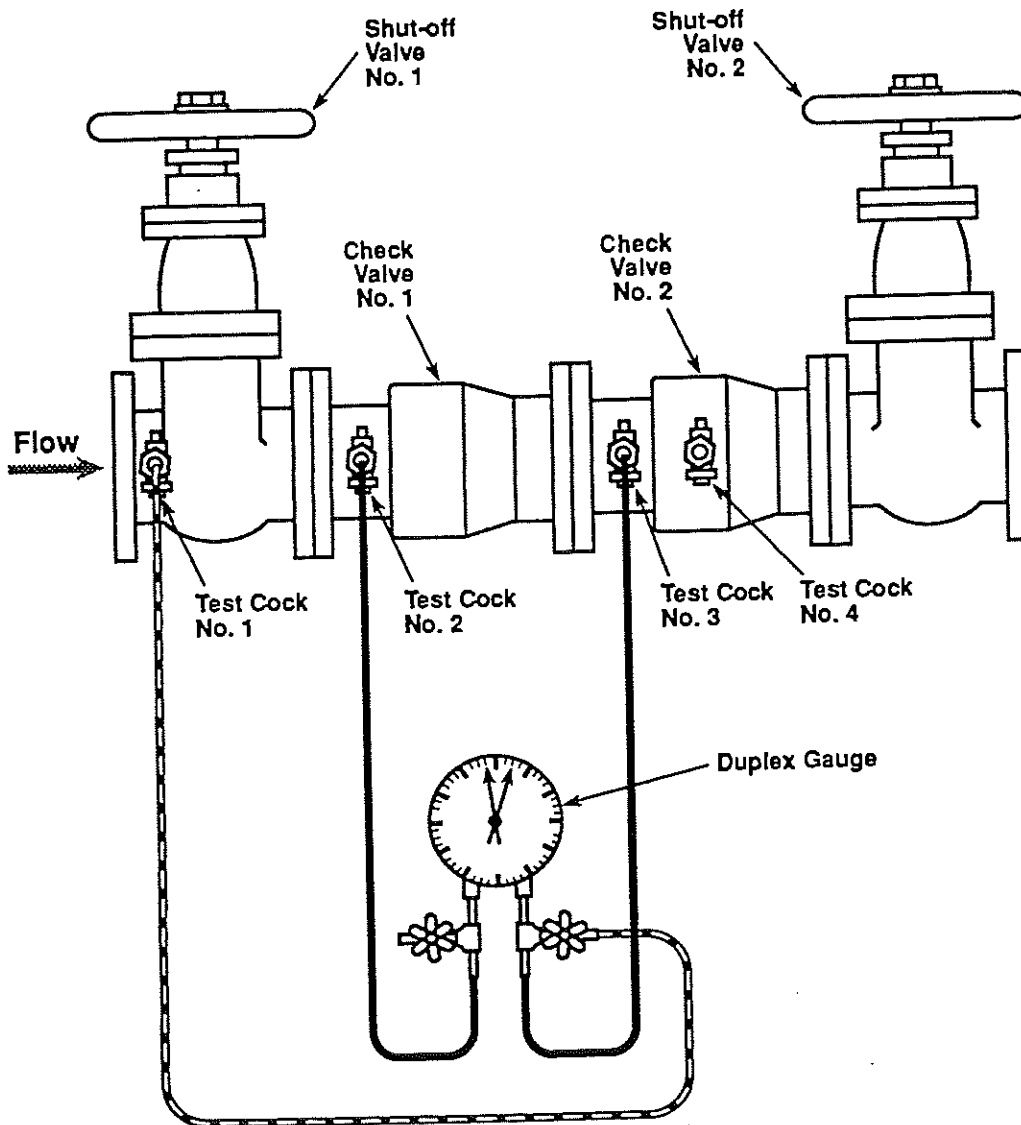

TEST CONNECTIONS FOR REDUCED PRESSURE PRINCIPLE BACKFLOW PREVENTER

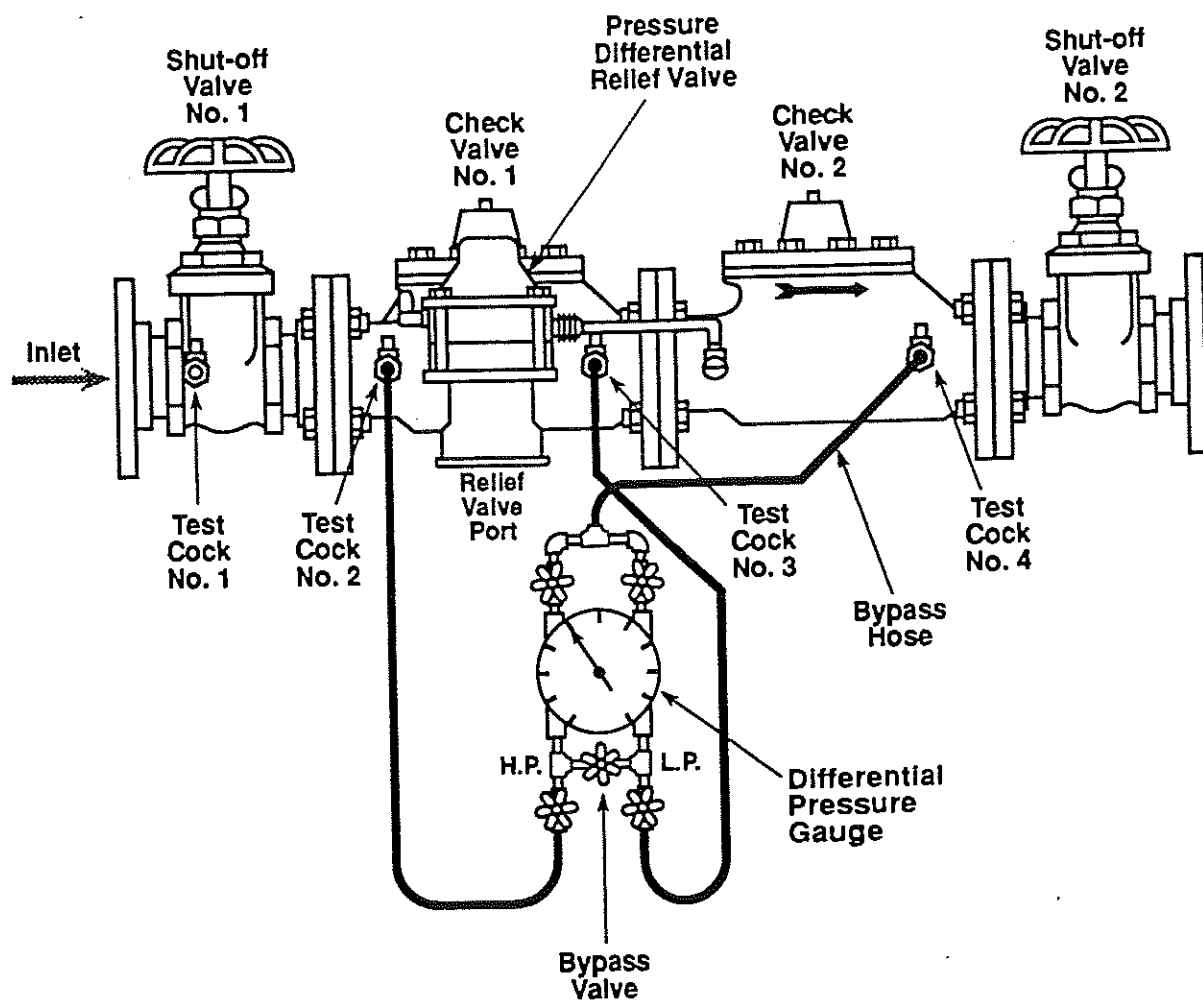

TYPICAL PIPING - 3" AND LARGER METER/BACKFLOW PREVENTER SETTINGS

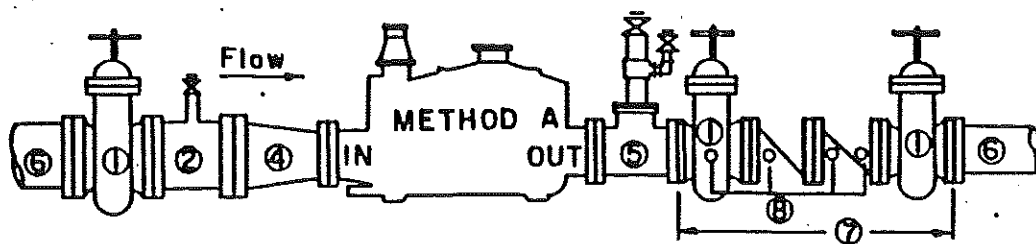

- ① Flanged Gate Valve Wheel Operator.
- ② Flanged Spool 6" Long With 1/2" Tapped Outlet.
- ③ Flanged Spool 12" Long With 1/2" Tapped Outlet.

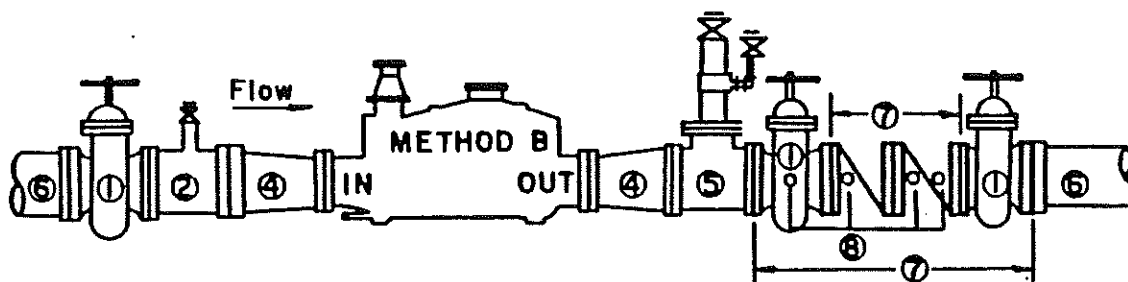

- ④ Flanged Reducing Spool.
- ⑤ Flanged Test Tee.
- ⑥ Flanged By Plain End Adapter 3' Or 6' Long.
- ⑦ Backflow Preventer. (No Smaller Than Meter Size).
- ⑧ Test Cock (See Notes).

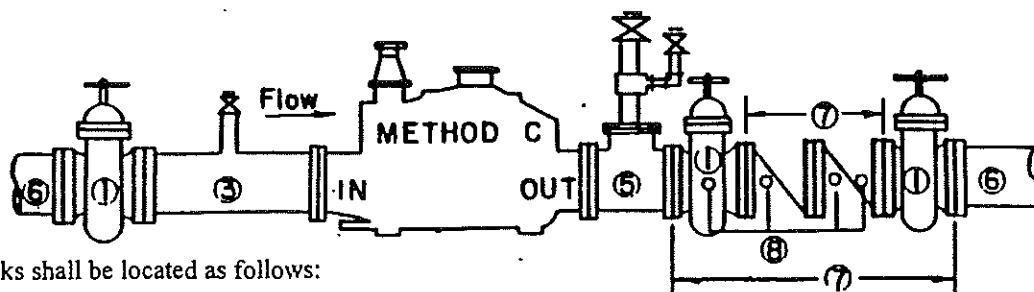

1. Test cocks shall be located as follows:

- a) Inlet side of the inlet valve of the backflow preventer
- b) Inlet side of check valve number 1
- c) Inlet side of check valve number 2
- d) Outlet side of check valve number 2

2. Test cock sizes shall be as follows:

- a) 1/4" for backflow preventers 2" and smaller
- b) 1/2" for 3" and 4" backflow preventers
- c) 3/4" for 6" and larger backflow preventers

TYPICAL PIPING - DETECTOR CHECK WITH BACKFLOW PREVENTER SETTING

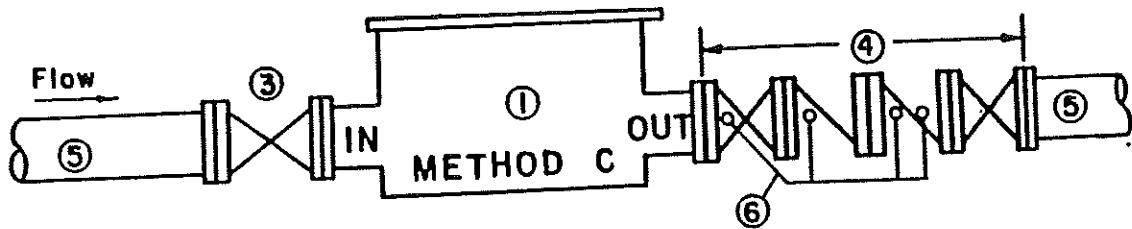
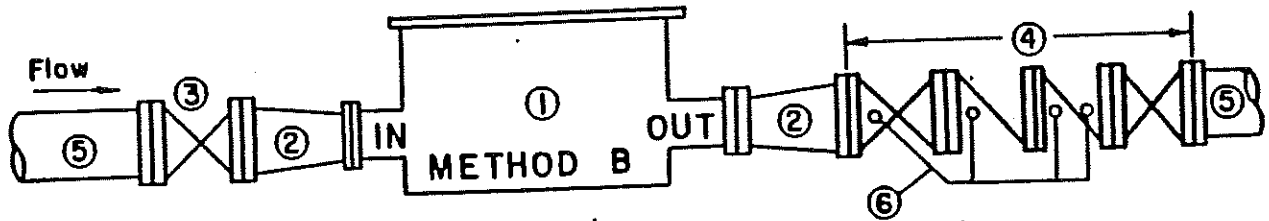
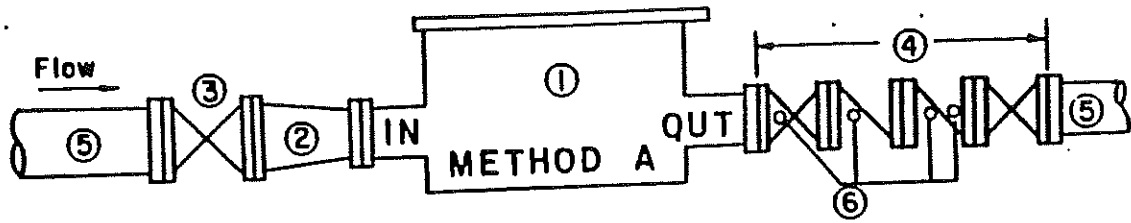

1. Test cocks shall be located as follows:

- a) Inlet side of the inlet valve of the backflow preventer
- b) Inlet side of check valve number 1
- c) Inlet side of check valve number 2
- d) Outlet side of check valve number 2

2. Test cock sizes shall be sized as follows:

- a) 1/4" for backflow preventers 2" and smaller
- b) 1/2" for 3" and 4" backflow preventers
- c) 3/4" for 6" and larger backflow preventers

BACKFLOW PREVENTION

=====

SECTION 9.

INSTALLATION

- A. Backflow prevention devices required by these rules and regulations shall be installed at a location and in manner approved by the Superintendent of water and at the expense of the water consumer. In addition, any backflow prevention device required by Section 7.B and 7.C of these regulations shall be installed at a location and in a manner approved by the Director of the Ohio Environmental Protection Agency as required by Section 6109.13 of the Ohio Revised Code.
- B. Backflow prevention devices installed on the service line to a consumer's water system shall be located on the consumer's side of the water meter, as close to the meter as is reasonably practical, and prior to any other connection.
- C. Pits or vaults shall be of water-tight construction, be so located and constructed as to prevent flooding and shall be maintained free from standing water by means of either a sump and pump or a suitable drain. Such sump pump or drain shall not connect to a sanitary sewer not permit flooding of the pit or vault because of reverse flow from its point of discharge. An access ladder and adequate natural or artificial lighting shall be provided to permit maintenance, inspection and testing of the backflow prevention device.
- D. Reduced pressure principle backflow prevention devices must be installed above ground level or floor level, whichever is higher.

TYPICAL INSIDE SETTING OF A BACKFLOW PREVENTER

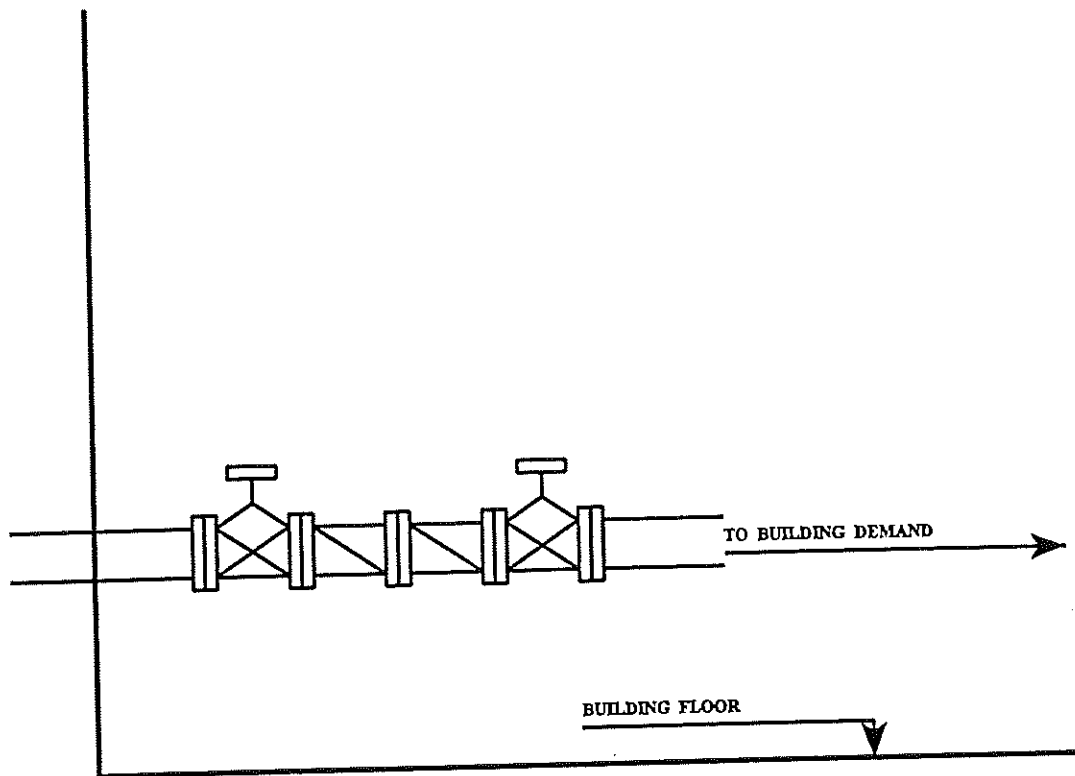

1. Any backflow preventer must be installed inside the building unless the Water Department approves an alternate location.
2. The backflow preventer must be installed immediately downstream of the water meter; if the water meter is in a pit then the backflow preventer must be installed immediately as the service piping enters the building.
3. The service piping between the meter and the backflow preventer must be void of branches or outlets of any type.
4. The backflow preventer must be installed a minimum of 6" from the wall and 24" from the floor.
5. The backflow preventer must be installed in a horizontal plane.
6. All test cocks must face the center of the room unless they are mounted in the top or bottom of the assembly.
7. The backflow preventer may be no smaller than the water meter size unless a manifold or parallel setting of backflow preventers is installed.
8. If a manifold or parallel setting is installed, then the combined flow rate of the assemblies must equal or exceed the flow rate of a single assembly setting.
9. The backflow preventer must be of a type approved by the Ohio EPA and the Water Department.
10. Water will be spilled during the normal operation of a reduced pressure backflow preventer and during the periodic testing of all backflow preventers; for this reason it is recommended that a floor drain be installed as close as practical to the assembly.
11. The relief valve discharge of a reduced pressure backflow preventer may be piped to a floor drain provided an approved air gap separation is maintained at the point of connection to the relief valve discharge.

DETERMINING MINIMUM AIR GAPS FOR PLUMBING FIXTURES

FIXTURE	MINIMUM AIR GAP	
	When not affected by near wall (1)	When affected by near wall (2)

Lavatories and other fixtures with effective openings not greater than ½" diameter	1"	1 ½"
Sinks, laundry trays, goose-neck bath faucets and other fixtures with effective openings not greater than ¾" diameter	1 ½"	2 ¼"
Over rim bath fillers and other fixtures with effective openings not greater than 1" diameter	2"	3"
Effective openings greater than the one inch opening	2X diameter of the effective opening	3X diameter of effective opening

- 1) Side walls, ribs or similar obstructions do not effect air gaps when spaced from the inside edge of spout opening a distance greater than three times the diameter of the effective opening for a single wall, or a distance greater than four times the diameter of the effective opening for two intersecting walls.

- 2) Vertical walls, ribs or similar obstructions extending from the water surface to or above the horizontal plane of the spout opening require a greater air gap when spaced closer to the nearest inside edge of the spout opening than specified in (1) above. The effect of three or more such vertical walls or ribs has not been determined. In such cases, the air gap shall be measured from the top of the wall.

BACKFLOW PREVENTION

=====
SECTION 10.

INSPECTION AND MAINTENANCE

- A. It shall be the duty of the consumer at any premises on which backflow prevention devices required by these regulations are installed to have inspections, tests, and overhauls made in accordance with the following schedule, or more often where inspections indicate a need:
1. Air gap separations shall be inspected at the time of installation and at least every twelve months thereafter;
 2. Double check valve assemblies shall be inspected and tested for tightness at the time of installation and at least every twelve months thereafter;
 3. Reduced pressure principle backflow prevention devices shall be inspected and tested for tightness at the time of installation and at least every twelve months thereafter.

They shall be dismantled, inspected internally, cleaned and repaired whenever needed and at least every five years.
 4. Interchangeable connections shall be inspected at the time of installation and at least every twelve months thereafter.
- B. Inspection tests, and overhauls of backflow prevention devices shall be made at the expense of the water consumer and shall be performed by the Superintendent of Water or a person approved by the Superintendent of Water as qualified to inspect, test and overhaul backflow prevention devices. Certification approval is required.
- C. Whenever backflow prevention devices required by these regulations are found to be defective, they shall be repaired, overhauled or replaced at the expense of the consumer without delay.
- D. The water consumer must maintain a complete record of each backflow prevention device from purchase to retirement. This shall include a comprehensive listing that includes a record of all tests, inspections, repairs and overhauls. Records of inspections, tests, repairs and overhaul shall be submitted to the Superintendent of Water.
- E. Backflow prevention devices shall not be bypassed, made inoperative, removed or otherwise made ineffective without specific authorization by the Superintendent of Water.

APPROVED AIR GAP SEPARATION REPORT

Premises Address: _____ Company Name: _____
 Contact Name: _____ Contact PhoneNo: _____
 Location of Air Gap Separation: _____
 Service Number: _____ Meter Number: _____ Date Installed: _____
 Type of Inspection: Initial _____ Annual _____ Date of Inspection: _____

I certify that the air gap separation as described above was inspected by me on the date as indicated and the following findings were made:

_____ Effective diameter of the supply pipe or opening
 _____ Near wall distance, if applicable
 _____ Height of supply opening above the flood-level rim

YES NO

_____ An approved minimum air gap separation is provided
 _____ The air gap separation is not bypassed
 _____ There is no indication that the air gap separation has been bypassed

COMMENTS: _____

INSPECTOR: Signature _____ Printed Name _____

Cert. Tester No: _____ Date: _____

I certify that the foregoing inspection was performed on the date indicated and that the following statement is true. The air gap separation as described above has been in uninterrupted use during the entire prescribed interval between inspections and that during that period has not been bypassed or otherwise made ineffective.

Company Representative: Name (Please Print) _____ Date _____

Signature _____ Title _____

INTERCHANGEABLE CONNECTION INSPECTION REPORT

Premises Address: _____ Company Name: _____
 Contact Name: _____ Contact PhoneNo: _____
 Location of Interchangeable Connection: _____
 Type of Connection: 4-Way _____ Swing _____ Service Number: _____ Meter Number: _____
 Type of Inspection: Initial _____ Annual _____ Date of Inspection: _____

I certify that the interchangeable connection as described above was inspected by me on the date indicated and the following findings were made.

YES	NO	
_____	_____	The interchangeable connection was found to be properly installed in accordance with the requirements of the Ohio Environmental Protection Agency and the plans as approved
_____	_____	The interchangeable connection has not been bypassed, removed or relocated
_____	_____	The reduced pressure principle backflow preventer, installed as part of the interchangeable connection has been tested for tightness and proper operation (test report attached).

COMMENTS: _____

INSPECTOR: Signature _____ Printed Name _____
 Cert. Tester No: _____ Date: _____

I certify that the foregoing inspection was performed on the date indicated and that the following statement is true. The interchangeable connection as described above has been in uninterrupted use during the entire prescribed interval between inspections and that during that period has not been bypassed or otherwise made ineffective.

Company Representative: Name (Please Print) _____ Date _____
 Signature _____ Title _____

VACUUM BREAKER INSPECTION / TEST REPORT

Premises Address: _____ Company Name: _____
 Contact Name: _____ Contact PhoneNo: _____
 Service Number: _____ Meter Number: _____ Date Installed: _____
 Type of Inspection: Initial _____ Annual _____ Date of Inspection: _____

Vacuum Breaker 1

Vacuum Breaker 2

	Vacuum Breaker 1	Vacuum Breaker 2
Type of Device		
Manufacturer		
Model		
Serial Number		
Size		
Location of Device		
Height above highest outlet		
External Inspection		
Internal Inspection		
Test Results		
Air Inlet Opening		
1st Check Valve Diff		
2nd Check Valve Diff		
Cleaned		
Repaired		
Replaced		
Pass/Fail		

I certify that the vacuum breaker inspection(s) / test(s) as described above was performed by me on the date indicated and the findings were as indicated:

COMMENTS: _____

INSPECTOR: Signature _____ Printed Name _____

Cert. Tester No: _____ Date: _____

I certify that the foregoing inspection was performed on the date indicated and that the following statement is true. The vacuum breaker(s) as described above has been in uninterrupted use during the entire prescribed interval between inspections and that during that period has not been bypassed or otherwise made ineffective.

Company Representative: Name (Please Print) _____ Date _____
 Signature _____ Title _____

DOUBLE CHECK BACKFLOW PREVENTER TEST REPORT

Premises Address: _____ Company Name: _____
 Contact Name: _____ Contact PhoneNo: _____
 Type of Inspection: Initial _____ Annual _____ Date of Inspection: _____
 Type of Device: _____ Model No: _____ Size: _____

	CHECK VALVE NO. 1	CHECK VALVE NO. 2
TEST BEFORE REPAIR	LEAKED _____ CLOSED TIGHT _____	LEAKED _____ CLOSED TIGHT _____
DESCRIBE REPAIRS		
MATERIALS USED		
FINAL TEST	CLOSED TIGHT _____	CLOSED TIGHT _____

I certify that the double check backflow preventer test as described above was performed by me on the date indicated and the results were as indicated:

COMMENTS: _____

INSPECTOR: Signature _____ Printed Name _____

Cert. Tester No: _____ Date: _____

I certify that the foregoing inspection was performed on the date indicated and that the following statement is true. The double check backflow preventer as described above has been in uninterrupted use during the entire prescribed interval between tests and that during that period has not been bypassed or otherwise made ineffective.

Company Representative: Name (Please Print) _____ Date _____
 Signature _____ Title _____

REDUCED PRESSURE PRINCIPLE BACKFLOW PREVENTER TEST REPORT

Premises Address: _____ Company Name: _____
 Contact Name: _____ Contact PhoneNo: _____
 Type of Inspection: Initial _____ Annual _____ Date of Inspection: _____
 Type of Device: _____ Model No: _____ Size: _____
 Location of Device: _____

	CHECK VALVE NO. 1	CHECK VALVE NO. 2	DIFFERENTIAL RELIEF VALVE
INITIAL TEST	APPARENT STATIC DROP _____ LEAKED YES(____) NO(____) ACTUAL STATIC DROP _____	CLOSED TIGHT (____) LEAKED (____)	OPENED AT (____) psid DID NOT OPEN (____)
DESCRIBE REPAIRS			
MATERIALS USED			
FINAL TEST	APPARENT STATIC DROP _____ ACTUAL STATIC DROP _____	CLOSED TIGHT (____)	OPENED AT (____) psid

I certify that the reduced pressure principle backflow preventer test as described above was performed by me on the date indicated and the results were as indicated:

COMMENTS: _____

INSPECTOR: Signature _____ Printed Name _____

Cert. Tester No: _____ Date: _____

I certify that the foregoing inspection was performed on the date indicated and that the following statement is true. The reduced pressure principle backflow preventer as described above has been in uninterrupted use during the entire prescribed interval between tests and that during that period has not been bypassed or otherwise made ineffective.

Company Representative: Name (Please Print) _____ Date _____
 Signature _____ Title _____

LOW PRESSURE CUT-OFF CONTROLLER TEST REPORT

Premises Address: _____ Company Name: _____
 Contact Name: _____ Contact Phone No: _____
 Type of Controller: Fire Pump _____ Domestic Booster Pump _____ Pressure Sustaining Valve _____
 Manuf: _____ Model No: _____ Serial No: _____
 Type of Inspection: Initial _____ Annual _____ Date of Inspection: _____

YES	NO	
_____	_____	Found the sensing line seal intact
_____	_____	Found the normal power light (green) on

MANUAL START

_____	_____	Low suction light (red) comes on when suction pressure reaches 10 psig
_____	_____	The alarm sounds after a minimum 30 second delay
_____	_____	The pump shuts off immediately after the low suction pressure alarm sounds
_____	_____	The pump does not automatically restart when the sensing line is recharged

AUTOMATIC START

_____	_____	Low suction light (red) comes on when suction pressure reaches 10 psig
_____	_____	The alarm sounds after a minimum 30 second delay
_____	_____	The pump shuts off immediately after the low suction pressure alarm sounds
_____	_____	The pump does not automatically restart when the sensing line is recharged

SUPERVISORY POWER

_____	_____	Found the supervisory power light (white) on
_____	_____	Turned normal power off, supervisory light remained on, and alarm sounds
_____	_____	Turned supervisory power off, normal power light remained on, alarm sounds

RESET PUMP

_____	_____	Opened outlet valve at pump discharge
_____	_____	Pump restarted in manual start mode
_____	_____	Pump restarted in automatic start mode
_____	_____	Resealed sensing line valve in open position

I certify that the low pressure cut-off controller test as described above was performed by me on the date indicated and the findings were as indicated:

COMMENTS: _____

INSPECTOR: Signature _____ Printed Name _____
 Cert. Tester No: _____ Date: _____

I certify that the foregoing inspection was performed on the date indicated and that the following statement is true. The low pressure cut-off controller as described above has been in uninterrupted use during the entire prescribed interval between inspections and that during that period has not been bypassed or otherwise made ineffective.

Company Representative: Name (Please Print) _____ Date _____
 Signature _____ Title _____

BACKFLOW PREVENTION

=====

SECTION 11.

BOOSTER PUMPS

- A. Where a booster pump has been installed on the service line to or within any premises, such pump shall be equipped with a low pressure cut-off device designed to shutoff the booster pump when the pressure in the service line on the suction side of the pump drops to ten pounds per square inch gauge or less.

- B. It shall be the duty of the water consumer to maintain the low pressure cut-off device in proper working order and to certify to the Superintendent of Water, at least once a year, that the device is operating properly.

SPECIFICATION FOR LOW SUCTION PRESSURE CUT-OFF CONTROLLER FIRE PUMP

The low suction pressure cut-off controller is designed to shut down fire pumps receiving water from a municipal water supply when the water supply pressure reduces to 10 psig at the suction side of the pump. The controller shall be of the type that, failure of electrical power to the controller will initiate an alarm.

The controller shall include the following components and requirements:

1. A pressure switch shall be located on the outside of the controller enclosure. The switch must be actuated by adequate water pressure before the fire pump controller can be operated. The pressure switch shall be provided with a tamper-proof seal on the adjustments.
2. A timer shall delay shut down of the fire pump controller for thirty (30) seconds after a low water pressure condition is sensed or detected.
3. The low suction pressure controller electrical power supply shall be obtained from the main fire pump controller circuit or from the fire pump controller supply circuit, incorporating a separate step-down transformer and shall not exceed 120 volts nominal.
4. Supervisory electrical power to the low suction controller shall be provided. It shall be from a separate reliable source and shall not exceed 120 volts nominal.
5. The following visual signals shall be provided on the cover of the cover of the controller box and marked as follows:
 - A. "Supply Power Normal" -- Green Pilot Light
 - B. "Supervisory Power Normal" -- White Pilot Light
 - C. "Low Suction Pressure" (without time delay) -- Red Pilot Light
6. The following audible alarm signals shall be provided in the controller:
 - A. Low Suction Pressure -- (after 30 second delay)
 - B. Supply Power Failure
 - C. Supervisor Power Failure
7. The audible alarm signal shall be energized through an electro-mechanical device.
8. Controller shall be provided with a manual "Alarm Silence" device, which shall be reactivated upon any alarm condition.
9. The controller shall conform to the requirements of the National Electrical Code (NFPA 70) and the Underwriters Laboratories Standard #508.
10. All electrical components shall be UL listed or UL recognized.

11. Supply and Supervisory power to the controller shall be fused within one controller.
12. A terminal strip shall be provided for all field connections.
13. The controller enclosure construction shall be in accordance with Nema Type 12 with provisions for locking, and painted alarm red. The controller shall be marked: "Fire Pump Low Suction Pressure Controller".
14. The pressure sensing line shall not be less than ½" diameter and, if a shut-off valve is included, it shall be sealed and locked in the open position. A test pressure gauge and drain valve shall be provided separate from the panel.

INSTALLING A LOW SUCTION PRESSURE CUT-OFF CONTROLLER

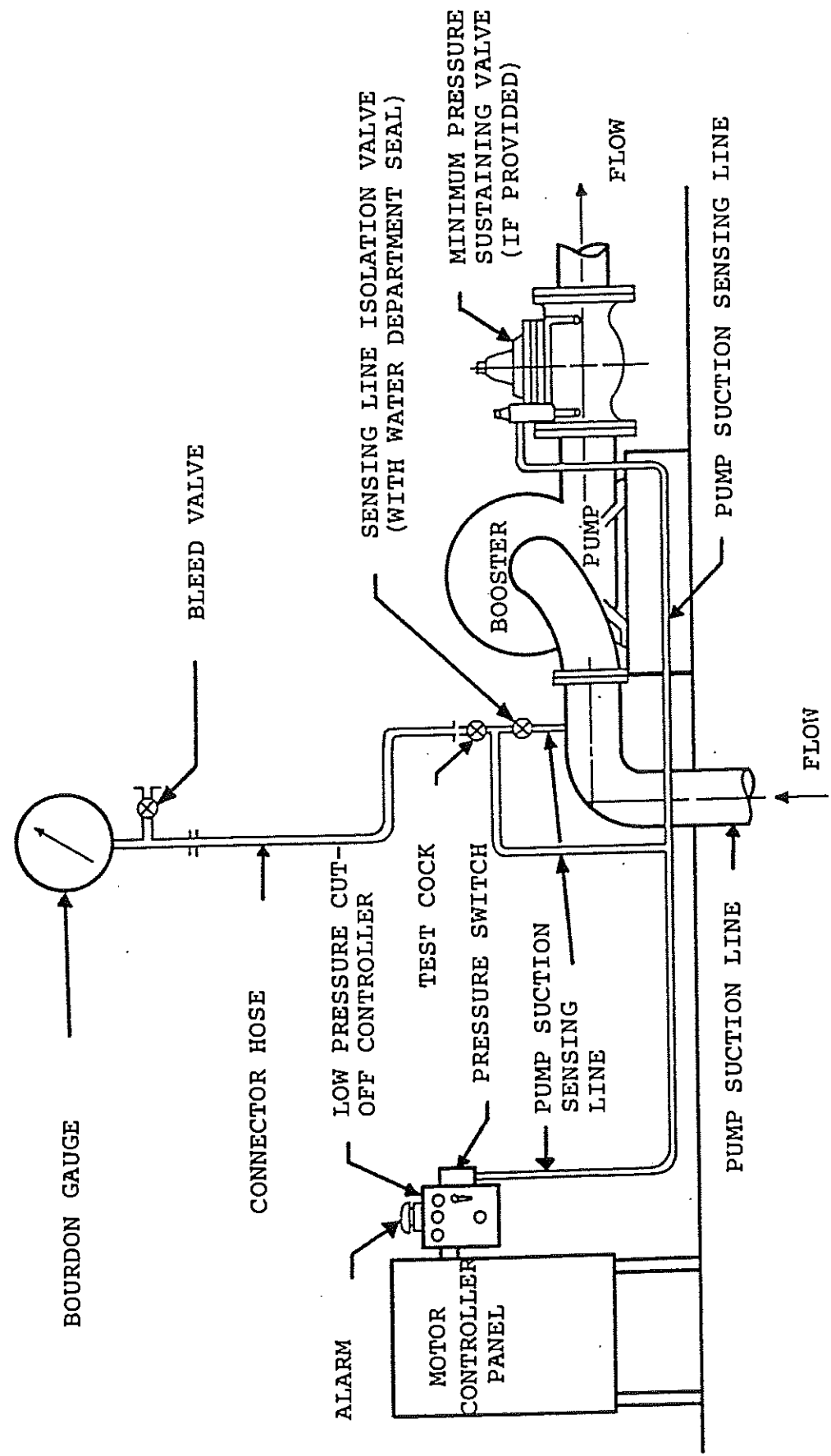

BACKFLOW PREVENTION

=====

SECTION 12.

VIOLATIONS

- A. The Superintendent of Water shall deny or discontinue, after reasonable notice to the occupants thereof, the water service to any premises wherein any backflow prevention device required by these regulations is not installed, tested and maintained in a manner acceptable to the Superintendent of Water, or if it is found that the backflow prevention device has been removed or by-passed, or if an unprotected cross-connection exists on the premises, or if a low pressure cut-off required by these regulations is not installed and maintained in working order.

- B. Water service to such premises shall not be restored until the consumer has corrected or eliminated such conditions or defects in conformance with these regulations and to the satisfaction of the Superintendent of Water.

APPENDIX: OHIO EPA APPROVED LIST

ATTACHMENT "A"

APPROVED BACKFLOW PREVENTION DEVICES

Note that all Ohio EPA-approved backflow prevention devices and assemblies include at least two shut-off valves and at least four test cocks. Some of the following model numbers can also designate products without shut-off valves or test cocks; products without shut-off valves or test cocks are not approved in this list.

REDUCED PRESSURE PRINCIPLE BACKFLOW PREVENTION DEVICES

<u>Company</u>	<u>Model</u>	<u>Sizes</u>
Ames Company, Inc.	4000 RP	4", 6", 8", and 10"
	4000 SS	3/4", 1", 1-1/2", 2", 2-1/2", 3", 4", and 6"
Buckner	24000	3/4"
	24001	1"
	24002	1-1/4"
	24003	1-1/2"
	24004	2"
CLA-VAL Company	RP-2	3/4", 1", 1-1/4", and 1-1/2"
	RP-4	2", 2-1/2", 3", 4", 6", 8", and 10"
	RP-4V	4"
	18-4	10"
Conbraco Industries, Inc.	40-201	1/4"
	40-202	3/8"
	40-203	1/2"
	40-204	3/4"
	40-205	1"
	40-207	1-1/2"
	40-208	2"
	40-209	2-1/2"
	40-200	3"
	40-20A	4"
	40-20C	6"
	40-20E	8"
	RPZ-40207 A2	1-1/2"
	40208 A2	2"
	4020G02	10"

ATTACHMENT "A"

REDUCED PRESSURE PRINCIPLE BACKFLOW PREVENTION DEVICES
(continued)

<u>Company</u>	<u>Model</u>	<u>Sizes</u>
FEBCO (CMB Industries)	825Y	3/4", 1", 1-1/4", 1-1/2", and 2"
	825YA	3/4", 1", 1-1/2", and 2"
	825YD	2-1/2", 3", 4", 6", 8", and 10"
Hersey Products a Grinnell Company	6C	1", 1-1/2", 2", 2-1/2", 3", 4", 6", 8", and 10"
	6CM	2-1/2", 3", 4", 6", 8", and 10"
	FRPII	3/4", 1", 1-1/4", 1-1/2", and 2"
Mueller Company*	H-9506	4", 6", 8", and 10"
Orion Industries, Inc.	80-0069	1-1/2"
	9-2929	2"
	BRP	3/4", 1", 3", and 4"
Rain Bird Sprinkler Manufacturing Corp.	RPA-075	3/4"
	RPA-100	1"
	RPA-150	1-1/2"
	RPA-200	2"
	RPA-250	2-1/2"
	RPA-300	3"
	RPA-400	4"
	RPA-600	6"
	RPA-800	8"
	RPA-1000	10"
	RP QT 075	3/4"
	RP QT 100	1"
	RP QT 125	1-1/4"
	RP QT 150	1-1/2"
	RP QT 200	2"
RP QT 250	2-1/2"	
RP QT 300	3"	

*No longer in production, parts still available.

ATTACHMENT "A"

REDUCED PRESSURE PRINCIPLE BACKFLOW PREVENTION DEVICES
(continued)

<u>Company</u>	<u>Model</u>	<u>Sizes</u>
Watts Regulator Company	009	1/2", 3/4", 1", 1-1/4", 1-1/2", 2", 2-1/2", and 3"
	909	3/4", 1", 1-1/4", 1-1/2", 2", 2-1/2", 3", 4", 6", 8", and 10"
	990RW	4", 6", and 8"
Wilkins Regulator Company	575	3/4", 1", 1-1/4", 1-1/2", 2", 3", 4", and 6"
	M-8 575	8"
	M-10 575	10"
	975	3/4", 1", 1-1/4", 1-1/2", 2", 2-1/2", 3", 4", 6", 8", and 10"
	975XL	3/4", 1", 1-1/4", 1-1/2", and 2"

ATTACHMENT "A"
DOUBLE CHECK VALVE ASSEMBLIES

<u>Company</u>	<u>Model</u>	<u>Sizes</u>
Ames Company, Inc.	2000 DCA	4", 6", 8", and 10"
	2000 SS	3/4", 1", 1-1/2", 2", 2-1/2", 3", 4", and 6"
	2000 SE	8"
Buckner	24100	3/4"
	24101	1"
	24102	1-1/4"
	24103	1-1/2"
	24104	2"
CLA-VAL Company	D-2	3/4", 1", 1-1/4", and 1-1/2"
	D-4	2", 2-1/2", 3", 4", 6", 8", and 10"
Conbraco Industries, Inc.	40-104	3/4"
	40-105	1"
	40-107	1-1/2"
	40-108	2"
	40-109	2-1/2"
	40-100	3"
	40-10A	4"
	40-10C	6"
	40-10E	8"
	40104A2	3/4"
	40105A2	1"
	40107A2	1-1/2"
	40108A2	2"
	4010G02	10"
FEBCO (CMB Industries)	805Y	3/4", 1", 1-1/2", and 2"
	805YD	2-1/2", 3", 4", 6", 8", and 10"
Hersey Products a Grinnel Company	FDC	3/4", 1-1/2", and 2"
	No. 2	3", 4", 6", 8", and 10"
	Hersey HDC	3/4", 1", 1-1/2", and 2"
ITT Grinnell Corporation	B-2	4", 6", 8", and 10"

ATTACHMENT "A"
DOUBLE CHECK VALVE ASSEMBLIES
 (continued)

<u>Company</u>	<u>Model</u>	<u>Sizes</u>
Mueller Company*	H-9505	4", 6", 8", and 10"
Orion Industries, Inc.	80-0060	3/4"
	9-2780	1"
	80-0070	1-1/2"
	9-2930	2"
	BDC	3/4", 1", 3" and 4"
Rain Bird Sprinkler Manufacturing Corp.	DCA-075	3/4"
	DCA-100	1"
	DCA-150	1-1/2"
	DCA-200	2"
	DCA-250	2-1/2"
	DCA-300	3"
	DCA-400	4"
	DCA-600	6"
	DCA-800	8"
	DCA-1000	10"
	DC QT 075	3/4"
	DC QT 100	1"
	DC QT 150	1-1/2"
	DC QT 200	2"
	DC QT 250	2-1/2"
DC QT 300	3"	
The Viking Corporation	A-1	4", 6", 8", and 10"
	B-1	4" and 6"
Watts Regulator Company	007	3/4", 1", 1-1/2", 2", 2-1/2", 3", and 4"
	709	3/4", 1", 1-1/4", 1-1/2", 2", 2-1/2", 3", 4", 6", 8", and 10"
	770 RW	4", 6", and 8"

*No longer in production, parts still available.

"Revised January 1993"

ATTACHMENT "A"
DOUBLE CHECK VALVE ASSEMBLIES
 (continued)

<u>Company</u>	<u>Model</u>	<u>Sizes</u>
Wilkins Regulator Company	550	3/4", 1", 1-1/4", 1-1/2", 2", 3", 4", 6", and 8"
	M-8 550	8"
	M-10 550	10"
	950	3/4", 1", 1-1/4", 1-1/2", 2", 2-1/2", 3", 4", 6", 8", and 10"
	950XL	3/4", 1", 1-1/4", 1-1/2", and 2"

ATTACHMENT "A"

DOUBLE CHECK-DETECTOR CHECK ASSEMBLIES

A double check-detector check assembly is a carefully matched assembly of a modified line-size double check valve assembly with a bypass containing a water meter and an approved double check valve assembly. The water meters usable with each approved assembly are listed after the size of the line-size assembly. If we have been notified which meter was used in getting approval, the letter for that meter is printed first and followed by a semicolon.

<u>Company</u>	<u>Model</u>	<u>Sizes</u>	<u>Approved Meters*</u>
Ames Company, Inc.	3000 DCDA	4", 6", and 8" 10"	B, D, F-L, N-O, Q A-B, D-L, N-Q
	3000 SS	2-1/2", 3", 4", and 6"	A-Q
	3000 SE	8"	A-Q
CLA-VAL Company	16	4", 6", 8", and 10"	D; D-Q
Conbraco Industries, Inc.	40-60A	4"	A-Q
	40-60C	6"	A-Q
	40-60E	8"	F-Q
	40-60G	10"	F-Q
EBCO (CMB Industries)	806YD	3"	M; B-Q
		4", 6", 8", and 10"	L; A-Q
Hersey Products a Grinnell Company	DDC-II	3"	Q; A-B, D-Q
		4", 6", and 8"	I; I-Q
		10"	Q; B, D-Q
Watts Regulator Company	007 DCDA	4"	N; A-Q
	709 DCDA	3"	N; B, D-L, N-O, Q
		4", 6", and 8"	N; A-B, D-L, N-O, Q
		10"	N; F-L, N-O, Q
770 DCDA	4", 6", and 8"	A, B, D-G, I, J, L, N, O, Q	
Wilkins Regulator Company	DCDA	2-1/2", and 3"	P; B-Q
		4"	M; A-Q
		6"	M; A-Q
	950 DA	4", 6", 8", and 10"	Not Provided

*Meter Identification:

(A) Hersey Model F-F 5/8" x 3/4"	(G) Precision 5/8"	(M) Neptune T-10 5/8"
(B) Hays Acumeter 5/8" x 3/4"	(H) Rockwell 5/8"	(N) Badger Model 25 3/4"
(C) Master Meter 5/8"	(I) Hersey Model 430 5/8"	(O) Kent Model C700 5/8" x 3/4"
(D) Carlon 5/8"	(J) Neptune Trident 8 5/8"	(P) Rockwell Model SR 3/4" Short
(E) Dande' Model D-3 5/8" x 3/4"	(K) Neptune 5/8"	(Q) Hersey Model MVR-30 3/4"
(F) Gamon-Calmet 5/8"	(L) Arad 5/8" x 3/4"	

ATTACHMENT "A"

REDUCED PRESSURE DETECTOR ASSEMBLIES

A reduced pressure detector assembly is a carefully matched assembly of a modified line-size reduced pressure assembly with a bypass containing a water meter and an approved reduced pressure assembly. The water meters usable with each approved assembly are listed after the size of the line-size assembly. If we have been notified which meter was used in getting approval, the letter for that meter is printed first and followed by a semicolon.

<u>Company</u>	<u>Model</u>	<u>Sizes</u>	<u>Approved Meters*</u>
Ames Company, Inc.	5000 RPDA	4"	M; N-Q
		6"	G; A-Q
8"		G; A-Q	
10"		M; A-Q	
	5000 SS	2-1/2", 3", 4", and 6"	A-Q
CLA-VAL Company	18-4	10"	D; D-Q
FEBCO	826YD	2-1/2", 3", 4", 8", and 10"	M; B-Q
Hersey Products a Grinnell Company	6CM-RPDA	4", 6", 8", and 10"	M; B-Q
Watts Regulator Company	909RPDA	3"	N; B-Q
		4"	N; B-Q
		6"	N; B-Q
		8"	N; B-Q
		10"	N; B-Q
	990RPDA	4"	A-Q

*Meter Identification:

(A) Hersey Model F-F 5/8" x 3/4"	(G) Precision 5/8"	(M) Neptune T-10 5/8"
(B) Hays Acumeter 5/8" x 3/4"	(H) Rockwell 5/8"	(N) Badger Model 25 3/4"
(C) Master Meter 5/8"	(I) Hersey Model 430 5/8"	(O) Kent Model C700 5/8" x 3/4"
(D) Carlon 5/8"	(J) Neptune Trident 8 5/8"	(P) Rockwell Model SP 3/4" Short
(E) Dande' Model D-3 5/8" x 3/4"	(K) Neptune 5/8"	(Q) Hersey Model MVR-30 3/4"
(F) Gamon-Calmet 5/8"	(L) Arad 5/8" x 3/4"	

WOOD COUNTY REGIONAL WATER AND SEWER DISTRICT

**Cross-Connection Control Program
And Containment Device Program**

Resolution #95-13

Backflow Prevention

WOOD COUNTY REGIONAL WATER AND SEWER DISTRICT CROSS-CONNECTION CONTROL PROGRAM OUTLINE

- Step 1:** Cross-Connection Questionnaire completed by water tap applicant, then forwarded to the Wood County Regional Water & Sewer District,
- Step 2:** The Wood County Regional Water & Sewer District reviews the Cross-Connection Questionnaire and based on Ohio EPA Regulations (Chapter 3745-95), and Wood County Regional Water & Sewer District's Resolution #95-13, a determination can be made regarding the need for a backflow preventer on the main water service line. (additional information may be required from the applicant)
- Step 3:**
- (a) **NO: Backflow prevention IS NOT required.**
Wood County Regional Water & Sewer District mails copy of questionnaire and cover letter, to the tap applicant, stating that based on questionnaire results a backflow preventer will not be required, on the main water service line. (Correspondences and Questionnaire filed in No-Action File, at the Wood County Regional Water & Sewer District) **PROCESS COMPLETED**
 - (b) **YES: Backflow prevention IS required.**
Wood County Regional Water & Sewer District mails copy of questionnaire, Backflow Protection Requirement Form, and a cover letter, to the tap applicant, stating that based on questionnaire results a backflow preventer will be required on the main water service line. (Correspondences and Questionnaire filed in Action File, at the Division of Water Distribution) **CONTINUE TO STEP 5**
- Step 4:** Tap applicant must contact the Wood County Regional Water & Sewer District within five (5) working days to notify that the correspondence has been received, the information on the questionnaire is correct and understood. If the Wood County Regional Water & Sewer District is not contacted within five (5) working days, a Wood County Regional Water & Sewer District employee shall attempt to make contact.
- Step 5:** The Wood County Regional Water & Sewer District shall inspect the backflow assembly installation at the time the meter setting is requested. If backflow preventer is not installed, meter will not be set. The inspection by the Wood County Regional Water & Sewer District will assure the following:
- proper device has been installed
 - location of device

- clearances and drainage
- manufacturer, model, serial #, size
- miscellaneous considerations

Step 6: Meter setting completed, engineering section shall send a written notification, to the tap applicant, requesting testing of the backflow preventer, within the following time frame:

COMPLIANCE TIME

(First Notice) Testing must be completed by a certified tester and test report submitted to the Wood County Regional Water & Sewer District within twenty-one (21) days.

(Second Notice) Testing must be completed by a certified tester and test report submitted to the Wood County Regional Water & Sewer District within three (3) days.

(Final Notice) Testing must be completed by a certified tester and test report submitted to the Wood County Regional Water & Sewer District within forty eight (48) HOURS or water service to the premise shall be terminated.

Step 7: The Wood County Regional Water & Sewer District shall file device data, and notify owner on a 12 month basis that testing of the backflow prevention assembly must be performed.

DOMESTIC SERVICES

For any new domestic water service connection to the following list of facilities, regardless of on-site water use, an approved backflow prevention device, of the type designated, shall be installed on each domestic water service to the facility.

It should be noted, however, that this list should be used only as a general guide and that each proposed building will be considered separately by the plans submitted or an on-site inspection. If the building one proposes to construct, or bid, falls into one or more of these broad categories, it will be safe to assume that a backflow preventer will be required to protect the water system from the highest degree of hazard contained within the proposed structure.

Along the right margin you will notice the abbreviation of device required, which are:

- A.G. - Air Gap Separation
- R.P. - Reduced Pressure Principle Backflow Preventer
- D.C. - Double Check Valve Backflow Preventer

Industrial Facility (as defined by water purveyor)	RP
Hospitals	RP
Mortuaries	RP
Medical clinic, office, etc.	RP
Nursing and Convalescent Homes	RP
Laboratories	RP
Sewage Treatment Plants & Pumping Stations	RP
Car Washes	RP
Lawn Irrigation System	RP
Veterinary Establishment	RP
Film Laboratory or Processing Plant	RP
Commercial Leased Property	RP
Waterfront Facilities, Pier, Docks	RP
 Premises having or having access to a secondary source of water	 RP
 Premise having a steam boiler, cooling system, or hot water heating system where chemical water conditioners are used	 RP
Premise having submerged inlet to equipment	RP

FIRE SERVICES

For any new fire service connection, where one or more of the following conditions exist, an approved backflow prevention device, of the type designated, shall be installed on each fire service line, upon immediate entry to the facility.

It should be noted, however, that this list should be used only as a general guide and that each proposed building will be considered separately by the plans submitted or an on-site inspection. If the building one proposes to construct, or bid, falls into one or more of these broad categories, it will be safe to assume that a backflow preventer will be required to protect the water system from the highest degree of hazard contained within the proposed structure.

Along the right margin you will notice the abbreviation of device required, which are:

- A.G. - Air Gap Separation
- R.P. - Reduced Pressure Principle Backflow Preventer
- D.C. - Double Check Valve Backflow Preventer

- Fire system with any domestic water service connected DC
(domestic water system may also require backflow protection)
- Fire system containing jockey pump DC
(an auxiliary pump with high head and low capacity characteristics
to maintain elevated pressure in the fire system)
- Fire system containing any additive, such as, RP
corrosion inhibitors or anti-freeze
(even propylene glycol)
- Premise having or having access to a secondary source of water RP
which can potentially be used for fire protection
(any fire system connected to an auxiliary water supply must obtain approval from
the Ohio EPA and the Wood County Regional Water & Sewer District)

BACKFLOW TESTING COMPANIES

CONTRACTOR'S NAME	PHONE NUMBER
Armstrong Mechanical Sevices	666-1400
Campbell, Inc.	476-4444
Coyle Plumbing Heating & Mechanical, Inc.	476-1980
Dimech Services, Inc.	727-0111
Dunbar Mechanical, Inc.	537-1900
Fry Heating & Air Conditioning Co.	472-1106
GEM Industrial, Inc.	666-6554
Hank's Plumbing & Heating Co.	843-2222
Helm & Associates	893-7369
High Tech Plumbing	382-8434
Holgate Metal Febricators	1-264-2011
Honeywell, Inc.	473-9721
Imperial Plumbing	856-6883
Industrial Power Systems	531-3121
Dan MacDermid Plumbing & Heating, Inc.	248-4403
E. C. Neidhardt Plumbing, Inc.	726-2395
George F. Peters & Son Plumbing, Inc.	244-8771
VanVlerah Mechanical	219-665-2123
Wagner Plumbing & Heating, Inc.	478-8750
Warner Mechanical	1-246-4548
Bob Weaver & Son's Plumbing	535-6930
Jim Wing Plumbing Co.	475-2531

General Information Section

SERVICE ADDRESS: Street number and street name of premise connecting to public water system

CITY/TOWNSHIP: Township, village, or city name where premise is located (example: Millbury, Lake Township)

COUNTY: County name where premise is located (example: Lucas, Wood, Ottawa)

OWNER: Legal owner of premise where water connection is to be made

OWNER'S ADDRESS: Address of legal owner of premise

OWNER'S CITY/STATE/ZIP: City name, state name and zip code of legal owner of premise

OWNER'S PHONE: Phone number of legal owner of premise

PROPOSED TAP SIZE: Size of proposed water connection to public water system (example: 1", 2", 6")

PROPOSED METER SIZE: Size of meter to be installed at premise

CURRENTLY, ANY EXISTING WOOD COUNTY REGIONAL WATER AND SEWER DISTRICT WATER SERVICE CONNECTIONS: Are other public water service connections currently serving premises, if yes include tap sizes and if the existing and proposed water service connect interconnected

ANY OTHER WATER SOURCE SERVING PREMISE: Is the premise currently served by or have readily available any outside sources of water.

Residential Section

WOOD COUNTY REGIONAL WATER AND SEWER DISTRICT WATER USED FOR LAWN IRRIGATION SYSTEM: Is a lawn irrigation system proposed for the premise

IS WOOD COUNTY REGIONAL WATER AND SEWER DISTRICT WATER USED FOR ANY PURPOSE OTHER THAN CULINARY/DRINKING/SANITARY/LAWN IRRIGATION: Is water used on premise other than for culinary, drinking, sanitary or lawn irrigation, if yes, describe use.

Commercial/Industrial Section

USE OF PREMISE: Enter how premise will be used.

DOMESTIC SERVICE: Complete ALL questions if domestic water is serviced from proposed tap.

USE OF DOMESTIC WATER: Check all boxes that apply to how water is actually or can potentially be used at the premises. (If a box is checked, be sure to complete ALL follow-up questions)

PUMP ON DOMESTIC SERVICE LINE: Will domestic waterline have a pump installed for boosting pressure water purposes, such as, culinary/drinking, dishwasher, etc. (If checked, be sure to complete ALL follow-up questions)

FIRE SERVICE: Complete ALL questions if fire service from proposed tap.

TYPE OF FIRE SERVICE: Check appropriate box(es) for type of fire system serving premise

PROPOSED NUMBER OF YARD FIRE HYDRANTS: If fire system includes yard hydrants, enter number on grounds of premises

BOOSTER PUMP ON PROPOSED FIRE LINE: Will fire service line have a pump for boosting pressure installed

JOCKEY PUMP ON PROPOSED FIRE LINE: Will fire service line have a jockey pump installed

AUXILIARY WATER STORAGE FOR FIRE PROTECTION: Are any secondary sources of water serving premise for fire protection (if checked, be sure to complete ALL follow-up questions)

ANY EXISTING FIRE SYSTEMS: Is premise currently served by any existing fire system

INSTRUCTIONS FOR CROSS-CONNECTION QUESTIONNAIRE

PLEASE READ THIS ENTIRE PAGE BEFORE FILLING OUT THE CROSS-CONNECTION QUESTIONNAIRE, SEE BACK FOR ASSISTANCE IN COMPLETING QUESTIONNAIRE.

PURPOSE

The Cross-Connection Questionnaire provides the Wood County Regional Water & Sewer District with water use information on proposed new water service connections, to the public water system. Based on questionnaire results, Ohio EPA Regulations (3745-95), and the Wood County Regional Water & Sewer District can determine the degree of hazard a premise presents to the public water system. If contamination of the public water supply exists, the owner must immediately install an approved backflow prevention assembly, at his own expense. The installation of a backflow prevention assembly, on the water service line, allows one-way flow into the premise, and prevents potential contaminants, within the premise, from reaching the public water system. Information on the installation of backflow preventers, and general information on cross-connection control, can be obtained by visiting the Wood County Regional Water & Sewer District, or by calling (419) 354-9090.

RESULTS OF QUESTIONNAIRE

A notification of Cross-Connection Questionnaire results shall be provided, in writing, to the applicant and/or owner by mail, from the Wood County Regional Water & Sewer District.

FAILURE TO COMPLETE QUESTIONNAIRE

THE WOOD COUNTY REGIONAL WATER & SEWER DISTRICT MAY DENY OR DELAY WATER TAP CONNECTIONS TO ANY PREMISE IN WHICH THE CROSS-CONNECTION QUESTIONNAIRE HAS NOT BEEN FULLY OR ACCURATELY COMPLETED.

WOOD COUNTY REGIONAL WATER AND SEWER DISTRICT CROSS-CONNECTION QUESTIONNAIRE

GENERAL INFORMATION SECTION (Tap Applicant To Complete Entire General Information Section)

Service Address: _____ City/Township: _____ County: _____

Owner: _____ Owner's Address (if different from service address): _____

Owner's City/State/Zip: _____ Owner's Phone: _____

1) Proposed Tap Size: Domestic _____ in. Fire _____ in. 2) Proposed Meter Size: _____ in.

3) Currently, Any Existing Wood County Regional Water and Sewer District Service Connections: Yes No
If Yes, Domestic Size _____ in. Fire Size _____ in.

Is This Existing Service to be Interconnected with Proposed Service: Yes No

4) Any Other Water Source Serving Premise: Yes No If Yes, Well Cistern Other _____

RESIDENTIAL SECTION (Tap Applicant For Residential Home Must Complete This Entire Section, Please Sign And Date Back Of Form)

5) Wood County Regional Water & Sewer District Used for Lawn Irrigation System: Yes No

6) Wood County Regional Water & Sewer District Used for any purpose other than culinary/drinking/sanitary/lawn irrigation:

If Yes, List: _____

=====

I HEREBY CERTIFY THAT I AM ACTING AS AGENT FOR THE OWNER OF THE PREMISE LISTED, WITH THE FULL KNOWLEDGE AND CONSENT, AND THAT ALL INFORMATION FURNISHED IS COMPLETE AND CORRECT. AS THE OWNER'S AGENT I FURTHER ACKNOWLEDGE THAT INCOMPLETE OR INCORRECT INFORMATION MAY RESULT IN AN ADDITIONAL OR DIFFERENT REQUIREMENT IN SO FAR AS BACKFLOW PREVENTION DEVICES ARE CONCERNED.

SIGNATURE OF APPLICANT: _____ DATE: _____

PRINT NAME OF APPLICANT: _____

PRINT COMPANY NAME: _____

PRINT ADDRESS AND PHONE NUMBER OF APPLICANT: _____

